



# MANTRA<sup>LITE</sup>

## **Lighting Control for LEDs, Moving Lights & Dimmers**

### **User Manual**

LSC Control Systems ©  
+61 3 9702 8000  
[info@lsccontrol.com.au](mailto:info@lsccontrol.com.au)  
[www.lsccontrol.com.au](http://www.lsccontrol.com.au)



Version 4.01  
November 2024

## **Disclaimer**

LSC Control Systems Pty Ltd has a corporate policy of continuous improvement, covering areas such as product design and documentation. To achieve this goal, we undertake to release software updates for all products on a regular basis. In light of this policy, some detail contained in this manual may not match the exact operation of your product. Information contained in this manual is subject to change without notice.

In any event, LSC Control Systems Pty Ltd cannot be held liable for any direct, indirect, special, incidental, or consequential damages or loss whatsoever (including, without limitation, damages for loss of profits, business interruption, or other pecuniary loss) arising out of the use or the inability to use this product for its intended purpose as expressed by the manufacturer and in conjunction with this manual.

Servicing of this product is recommended to be carried out by LSC Control Systems Pty Ltd or its authorised service agents. No liability will be accepted whatsoever for any loss or damage caused by service, maintenance or repair by unauthorised personnel. In addition, servicing by unauthorised personnel may void your warranty.

LSC Control Systems' products must only be used for the purpose for which they were intended.

Whilst every care is taken in the preparation of this manual, LSC Control Systems takes no responsibility for any errors or omissions.

## **Copyright Notices**

“LSC Control Systems” is a registered trademark.

lsccontrol.com.au is owned and operated by LSC Control Systems Pty Ltd.

All Trademarks referred to in this manual are the registered names of their respective owners.

The operating software of the Mantra Lite and the contents of this manual are copyright of LSC Control Systems Pty Ltd © 2021.

All rights reserved.

## **Contact Details**

LSC Control Systems Pty Ltd

ABN 21 090 801 675

65-67 Discovery Road  
Dandenong South, Victoria 3175 Australia  
Tel: +61 3 9702 8000

email: [info@lsccontrol.com.au](mailto:info@lsccontrol.com.au)

web: [www.lsccontrol.com.au](http://www.lsccontrol.com.au)

## Contents

<b>1</b>	<b>Introduction.....</b>	<b>10</b>
1.1	Conventions Used in this Manual .....	10
1.2	Mantra Lite Overview.....	10
1.3	Latest Features.....	11
1.4	Expansion Wings.....	11
1.5	USB to DMX Node.....	12
1.6	Quick Start Guide .....	12
1.7	Sample Show .....	12
1.8	Visualiser.....	13
1.9	Training Videos.....	13
1.10	Models.....	13
1.11	Accessories .....	13
<b>2</b>	<b>Getting Connected .....</b>	<b>14</b>
2.1	Rear Panel Layout.....	14
2.2	Mains Input.....	14
2.3	Switching On .....	14
2.4	Switching Off .....	14
2.5	DMX 512 Output Connector.....	14
2.6	USB Connectors.....	14
2.7	Ethernet Network Connector.....	15
2.8	Kensington Lock Slot.....	15
2.9	Fuse .....	15
<b>3</b>	<b>Help and Undo .....</b>	<b>16</b>
3.1	Help.....	16
3.1.1	Languages.....	16
3.2	Undo.....	16
3.3	Reset.....	16
<b>4</b>	<b>Patching Fixtures .....</b>	<b>17</b>
4.1	Overview .....	17
4.2	Patching a fixture.....	18
4.3	Patching Multiple Fixtures in One Operation.....	19
4.4	Multi-Patch. Patching Multiple Fixtures to the Same Fader.....	20
4.5	Patching Compound Fixtures.....	20
4.6	View Patch .....	21
4.7	Un-Patching a Fixture(s).....	22
4.8	Un-patch a Multi-Patched Fixture .....	22
4.9	Save Patch .....	23
4.10	Home Values.....	23

4.11	Fixture Editor .....	23
4.12	Universes .....	24
4.12.1	sACN and ArtNet Output Rules .....	24
4.12.2	ArtNet Output .....	25
4.12.3	sACN Output .....	25
4.12.4	Override (Art-Net or sACN Input) .....	26
4.12.5	ArtNet Input .....	27
4.12.6	sACN Input .....	27
4.13	View DMX Output .....	28
<b>5</b>	<b>Front Panel .....</b>	<b>29</b>
5.1	Overview .....	29
5.2	Basic Operation .....	29
<b>6</b>	<b>Touch Screen .....</b>	<b>30</b>
6.1	Overview .....	30
6.2	Fixture Icons .....	31
6.3	Playback Displayers .....	31
<b>7</b>	<b>Rig View .....</b>	<b>33</b>
7.1	Overview .....	33
7.2	Arranging Icons .....	33
<b>8</b>	<b>Controlling Fixtures .....</b>	<b>34</b>
8.1	Intensity .....	34
8.2	Fixture Attributes .....	34
8.2.1	Intensity Column .....	35
8.2.2	Colour Column .....	35
8.2.3	Position Column .....	35
8.2.4	Beam / Other Column .....	35
8.3	Selecting Fixtures .....	35
8.4	Automatic Fixture De-select .....	37
8.5	Controlling Intensity .....	37
8.5.1	Intensity Sliders App .....	37
8.6	Controlling Colour .....	37
8.6.1	Picker App .....	37
8.6.2	Fine .....	38
8.6.3	Fan .....	38
8.6.1	Gels .....	39
8.6.2	Sliders .....	39
8.7	Controlling Position .....	40
8.7.1	Flip Pan/Flip Tilt .....	40
8.7.2	Centre .....	41

8.7.3	Fine Control.....	41
8.7.4	Ortho Control.....	41
8.7.5	Fan.....	41
8.8	Controlling Beam and Other Attributes .....	42
8.9	Clearing Fixtures .....	42
8.9.1	Clear All.....	43
8.9.2	Selective Clear .....	43
<b>9</b>	<b>Animate Apps .....</b>	<b>45</b>
9.1	Overview .....	45
9.2	Creating an Animation .....	45
9.3	Animation Controls .....	46
9.4	Animation Examples.....	46
9.4.1	Intensity Animation .....	47
9.4.2	Colour Animations .....	47
9.4.3	Pan/Tilt Animations.....	48
9.5	Multiple Animations .....	49
9.6	Recording Animations.....	49
9.7	Deleting Animations.....	49
9.8	Animations in a Chase.....	50
9.9	Animate Speed.....	50
<b>10</b>	<b>Shapes App.....</b>	<b>51</b>
10.1	Overview .....	51
10.2	Creating a Shape.....	51
10.3	Recording Shapes .....	52
10.4	Deleting Shapes .....	52
10.5	Shapes in a Chase .....	52
10.6	Shape Speed.....	52
<b>11</b>	<b>Recording Cues .....</b>	<b>53</b>
11.1	Overview .....	53
11.2	Memories / Pages.....	53
11.3	Record a Cue .....	53
11.4	Record a Cue-list (or Chase) .....	54
11.5	Record Fixtures with No Intensity .....	55
11.5.1	Move in Black.....	55
11.5.2	Solo Cue .....	55
<b>12</b>	<b>Playback.....</b>	<b>56</b>
12.1	Overview .....	56
12.2	Playback a Cue .....	56
12.2.1	Fade Times .....	56

- 12.3 Playback a Cue-List..... 57
- 12.4 Playback a Chase..... 57
  - 12.4.1 Fade Times ..... 57
  - 12.4.2 Link Times ..... 57
- 12.5 Page Freeze..... 57
- 12.6 Latest Takes Precedence ..... 58
- 12.7 ICPB Attributes (Filters) ..... 58
- 13 Edit Memory..... 59**
- 13.1 Overview ..... 59
- 13.2 Fade Times ..... 59
- 13.3 Link Time..... 60
- 13.4 Memory Name ..... 60
- 13.5 Cue Name ..... 60
- 13.6 Jump to Cue ..... 60
- 13.7 Change Cue Order ..... 60
- 13.8 Include ICPB Attributes (Filters)..... 60
- 13.9 Copy Cue ..... 61
- 13.10 Copy Memory..... 61
- 13.11 Delete Cue ..... 61
- 13.12 Delete Memory..... 61
- 13.13 Chase ..... 62
  - 13.13.1 Flash a Chase..... 63
- 13.14 Edit a Cue ..... 63
- 13.15 Edit Animations and Shapes ..... 63
- 14 Live Speed..... 64**
- 14.1 Overview ..... 64
- 14.2 Select ..... 65
- 14.3 Tap to Beat..... 65
- 14.4 Pause/Play ..... 65
- 14.5 Override Indicators ..... 66
- 14.6 Reset Live Speed ..... 66
- 15 Flash..... 67**
- 15.1 Flash Level..... 67
- 16 Remote Triggers..... 68**
- 16.1 Overview ..... 68
- 16.2 Network Connection ..... 68
- 16.3 Add a Remote Trigger ..... 69
  - 16.3.1 OSC Remote Triggers ..... 70
  - 16.3.2 UDP and TCP Remote Triggers ..... 71

- 16.3.3 Play Memory ..... 72
- 16.3.4 Other Cues Off ..... 74
- 16.3.5 Next Cue ..... 74
- 16.3.6 All Cues Off ..... 74
- 16.4 Remote Triggers and Red Playback Faders ..... 74
  - 16.4.1 Override Disable..... 75
- 16.5 Cue Change ..... 75
- 16.6 De-activate a Remote Trigger ..... 77
- 16.7 Devices that can send OSC Remote Trigger Messages ..... 77
  - 16.7.1 StreamDeck..... 77
  - 16.7.2 Touch OSC..... 79
- 17 Show Files ..... 81**
  - 17.1 Overview ..... 81
  - 17.2 New Show ..... 81
  - 17.3 Save Show ..... 81
  - 17.4 Save Show As ..... 81
  - 17.5 Load Show ..... 81
  - 17.6 Export Show to USB..... 81
  - 17.7 Import Show from USB..... 82
- 18 Mantra Editor Software ..... 83**
  - 18.1 Overview ..... 83
  - 18.2 Installing the Mantra Editor Software ..... 83
  - 18.3 Off Line Edit a Mantra Lite Show ..... 83
    - 18.3.1 Export a Show from Mantra Lite ..... 83
    - 18.3.2 Import a Show into Mantra Editor ..... 83
    - 18.3.3 Export a Show from Mantra Editor..... 84
    - 18.3.4 Import a show into the Mantra Lite..... 84
  - 18.4 On Line Edit a Mantra Lite Show ..... 84
    - 18.4.1 Connecting the Editor to the Mantra Lite via Ethernet..... 85
    - 18.4.2 Connecting the Editor to the Mantra Lite via Wi-Fi..... 86
    - 18.4.3 Output Priority ..... 88
    - 18.4.4 Disconnecting the Editor from the Mantra Lite ..... 88
  - 18.5 Mantra Editor Controls..... 89
    - 18.5.1 Keyboard Shortcuts ..... 89
    - 18.5.2 Editor Main Screen ..... 89
    - 18.5.3 Selecting Fixtures..... 90
    - 18.5.4 Controlling Intensity ..... 90
    - 18.5.5 Fixed Buttons ..... 90
    - 18.5.6 Apps..... 92

18.5.7	Edit (Update) a Cue .....	92
18.5.8	Edit Animations and Shapes.....	92
18.5.9	Mantra Mini Overview .....	93
<b>19</b>	<b>Setup .....</b>	<b>94</b>
19.1	Overview .....	94
19.2	Default Fade Time .....	94
19.3	Delete Custom Fixtures .....	94
19.4	Delete Show .....	95
19.5	Save Default Show .....	95
19.5.1	Default Show Emergency PIN .....	95
19.6	Delete Default Show .....	95
19.7	System Settings.....	95
19.7.1	Network .....	96
19.7.2	Language .....	96
19.7.3	Import Fixture Library .....	96
19.7.4	Service .....	96
19.7.5	Touch Screen Backlight.....	97
19.7.6	About.....	97
19.7.7	Update Firmware (Software).....	97
<b>20</b>	<b>Feature History.....</b>	<b>98</b>
<b>21</b>	<b>Fixture Editor.....</b>	<b>103</b>
21.1	Overview .....	103
21.2	Creating a Fixture Template .....	103
21.2.1	Home Positions .....	105
21.3	Edit a Fixture Template.....	105
<b>22</b>	<b>Visualiser.....</b>	<b>106</b>
<b>23</b>	<b>Troubleshooting .....</b>	<b>107</b>
23.1	FAQ.....	107
23.2	Rescue File .....	107
<b>24</b>	<b>Specifications.....</b>	<b>108</b>
<b>25</b>	<b>Terminology.....</b>	<b>109</b>
25.1	Overview .....	109
25.2	Fixture.....	109
25.3	DMX Address.....	109
25.4	Template.....	109
25.5	Fixture Library.....	109
25.6	Attribute.....	109
25.7	LTP. (Latest Takes Precedence) .....	109

25.8	Look .....	109
25.9	Cue.....	109
25.10	DMX512A .....	110
25.11	DMX Cables.....	110
25.12	DMX Universes .....	110
25.13	ArtNet.....	110
25.14	sACN .....	110
<b>26</b>	<b>Caring for your Mantra Lite .....</b>	<b>110</b>
<b>27</b>	<b>Compliance Statements .....</b>	<b>111</b>

## 1 Introduction

### 1.1 Conventions Used in this Manual

Throughout this manual, certain conventions have been used to make the meaning clearer.

- A word in **Bold** text represents a virtual button on the touch screen
- A word in [**Bold**] text with square brackets represents a physical button
- Emphasis is indicated by underlining
- *Notes or Hints are displayed in italic font*

### 1.2 Mantra Lite Overview

Mantra Lite combines the ease of use of a fader-based console, with the power of a touch screen graphical user interface to make control of LED fixtures easy and intuitive while still allowing control of moving lights and conventional dimmers. The software shows you what to do next, ensuring a very easy learning curve for even the novice user.



Mantra Lite can control 24 lighting fixtures of any type, dimmer, LED, moving LED and moving lights. “Expansion Wings” allow additional fixtures to be controlled. Faders are used to control intensity and the large touch screen has “Apps” that allow you to easily program colour, position or other attributes. The “Home” screen “rig view” has fixture icons showing intensity, colour and position of each fixture. The fixture icons can be positioned on the screen to emulate their actual position in your rig.

Mantra Lite makes controlling multi-colour LED fixtures easy. The different types of attributes (RGB, RGBA, RGBAW or CMY) are all controlled via a simple touch screen colour picker. Position (Pan and Tilt) is also controlled via the touchscreen and other attributes by virtual faders. This allows the Mantra Lite to control not just colour, but all the attributes of modern moving lights.

Where Mantra Lite really shines is in its effects. The unique Animate Apps provides a simple and intuitive way to quickly create chases and patterns in a single cue, usually within just a few seconds. This feature alone makes the Mantra Lite the most powerful in its class. The Shapes App provides a quick and simple way of creating continuously moving positions on fixtures that have Pan and Tilt attributes by constantly varying those attributes.

An Undo command system and context sensitive Help ensures that Mantra Lite is easy to use.

When you have adjusted the intensity and colour of your fixtures and possibly created animations or shapes you can record the current output onto any Red Playback fader. Mantra has the capacity to record up to 1,000 cues, across 100 cue-lists or chases.

Fixture library updates and new software features are easily installed via USB stick. Show files (that are stored in the console) can be backed up to USB stick for off-site storage.

Full brownout protection via on-board mini-UPS providing five seconds of power for automatic show save.

### 1.3 Latest Features

LSC Control Systems Pty Ltd has a corporate policy of continuous improvement covering areas such as product design and documentation. To achieve this goal, we undertake to release software updates for all products on a regular basis. Every software release includes the latest version of the Fixture Library.

This version of the manual covers up to version 3.06 of the software.

See section 20 for a full list of the features that were added in each software release.

### 1.4 Expansion Wings

The Mantra Wing is an accessory for the Mantra Lite lighting console. Up to 2 wings can be connected to a Mantra Lite console.

Connecting a Wing provides control of an additional 12 lighting fixtures (numbers 25 - 36) and a further 10 playbacks (11 - 20) (with 10 pages of memory) as well as a second DMX512 universe (U2) output.

Connecting a second Wing provides control of an additional 12 lighting fixtures (37 - 48) and a further 10 playbacks 21 - 30) (with 10 pages of memory) as well as a third DMX512 universe (U3) output.



**Mantra Lite with 2 Wings**



**Mantra Wing**

See the “Expansion Wing for the Mantra Lite” manual for more details.

## 1.5 USB to DMX Node

Connecting an LSC “QX1” USB to DMX512A adaptor provides an additional DMX universe output.



**QX1**

## 1.6 Quick Start Guide

A summary of the information in this “User Manual” can be found in the Mantra Lite “Quick Start Guide” supplied with your Mantra Lite and also available for download at the LSC website.

## 1.7 Sample Show

Mantra comes with a “Sample” show that you can load so that you can familiarise yourself with the controls before patching your own fixtures. To load the sample show from the “Home” screen touch: **Tools, Load, SampleShow.mtr, Load.**

If you do not need the sample show and want to patch your own fixtures now, go straight to section 4, “Patching Fixtures”.

The sample show is perfect for training and demonstration of the console.

The sample show is patched with the following fixtures:

- 6 x Dimmers patched to yellow faders 1-6
- 6 x RGB LED Par cans patched to yellow faders 7-12
- 8 x RGB cyc washes patched to yellow faders 13-20
- 4 Mac Aura moving lights patched to yellow faders 21-24

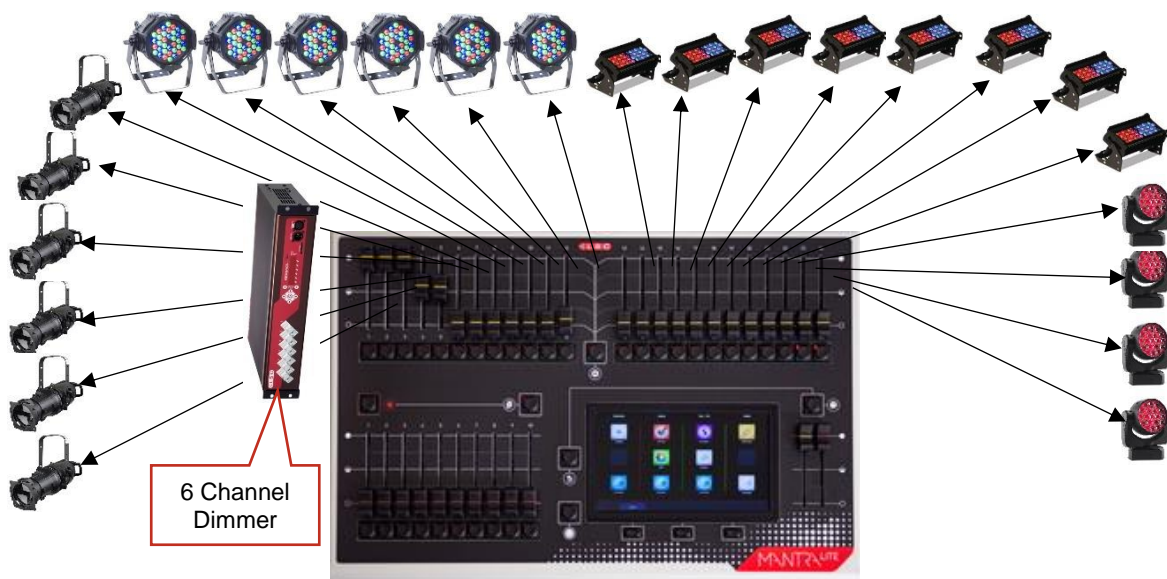

**Sample Show Fixtures**

There are some sample memories already recorded on Page 10 for experimentation. The other 9 pages of memory are blank.

## 1.8 Visualiser

If you would like to see a simulation of the fixtures in the sample show working on a virtual stage on your computer you can download a 3D visualiser lighting program called “Mantra Lite Visualisation show”. See section 22 for details.

## 1.9 Training Videos

An extensive set of training videos are available on the LSC website. The current video titles are:

- Overview
- Controlling Fixtures
- Recording Memories
- Animations
- Shapes
- Playback
- Patching a New Show
- Creating a Custom Fixture Template
- Saving your show
- Editing Recorded Memories
- Expanding the Mantra Lite with Wings
- User Settings

## 1.10 Models

Two models of Mantra Lite are available to suit world markets:

Model Order Code	Description
MANTRA/LT	Mantra Lite control console with built-in power supply 90-265V 50-60Hz.
MANTRA/LT/E	Mantra Lite control console with external power supply - UL Model for the North American market. Also suitable for 12-volt DC operation. External plug pack supplied suitable for use on 90-265V 50-60Hz mains supply.

## 1.11 Accessories

Model Order Code	Description
MANTRA/WG	Expansion wing for Mantra Lite console. Provides an additional 12 fixtures, 10 playbacks and 1 x DMX-512A output. USB powered. Up to 2 wings can be attached.
MANTRA/LTDC	Dust cover for Mantra Lite control console.
QX1	USB to DMX512A adaptor. Provides an additional DMX universe.

## 2 Getting Connected

### 2.1 Rear Panel Layout

Two models of Mantra Lite are available to suit world markets.

\* The MANTRA/LT has an inbuilt power supply with a mains input.

\* The MANTRA/LT/E (UL Model) uses an external power supply and has a DC Power socket in place of the power switch, fuse and mains input. It is intended for the North American market but can be used in any application that requires 12-volt DC operation.

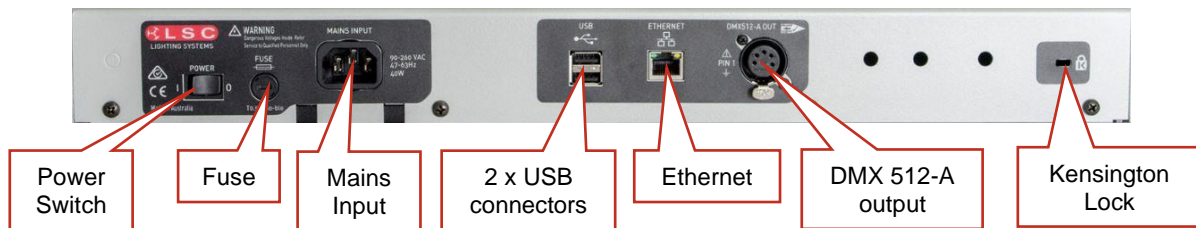

**MANTRA/LT Model**

### 2.2 Mains Input

An IEC mains input socket is located on the rear panel and a POWER switch is beside the power input (LT model only). Mantra Lite has a universal power supply that will operate on voltages between 100-240V AC with a frequency range from 47 to 63 Hz.

### 2.3 Switching On

Switch on the “POWER” switch on the rear of the Mantra Lite (LT model only). After briefly displaying the opening message, the Mantra Lite will commence operating in exactly the same state that it was in with all of the cues, animations and patches etcetera as they were when the Mantra Lite was last switched off.

### 2.4 Switching Off

The Mantra Lite has an inbuilt back up power supply. When the power is switched off (or accidentally removed), the Mantra Lite keeps operating on its own power supply for about 5 seconds to allow it to automatically save your work. If you are resetting the system by removing the power, allow about 15 seconds before re-starting to ensure that the system has fully shut down.

### 2.5 DMX 512 Output Connector

The Mantra Lite has a 5 pin DMX512-A output connector. Connect a DMX data cable from the DMX512-A output of the Mantra Lite to the DMX512 input of your equipment (LED fixtures, dimmers, etcetera.) and set the required DMX addresses on your equipment.

Only use specific DMX cable (available from your lighting supply company). Never use audio cable. The end of the DMX line must be terminated (120 ohms) to prevent the signal reflecting back up the line and causing possible errors.

See section 4 “Patching Fixtures” for more details.

See section 25.11 for more information on DMX cables.

### 2.6 USB Connectors

Two USB connectors are provided. They can be used to connect:

- A USB keyboard or mouse.
- A memory stick for show backup and software upgrades.

- A LED USB desk light (up to 250mA).
- Expansion wing. Up to two wings can be connected. Each wing provides an additional DMX universe.
- QX1 node (USB to DMX adaptor). Provides an additional DMX universe.

## **2.7 Ethernet Network Connector**

A RJ45 Ethernet network connector is provided.

It can be used to output Streaming ACN (sACN) and ArtNet. These are lighting control protocols that send DMX lighting data over a network. See section 19.7.1 for more details.

It can also be used for “Remote Triggers”. See section 16

## **2.8 Kensington Lock Slot**

The Kensington Lock slot allows you to secure your Mantra Lite using a commercially available tethering device.

## **2.9 Fuse**

A 0.5 Amp slow blow fuse is located near the mains input socket (LT model only). Always remove the mains lead before replacing the fuse.

## 3 Help and Undo

### 3.1 Help

Context sensitive help is available on the touch screen for most functions. Press the button to open the help screen. Press or [Back] to close.

#### 3.1.1 Languages

Help pages are available in several languages. To select a language, from the “Home” screen touch **Tools**, **Setup**, **System Settings**, **Language** then touch the language of your choice.

### 3.2 Undo

To quickly undo your last action double tap .

All of your actions are tracked on the Mantra Lite. Press once to see the list of your actions.

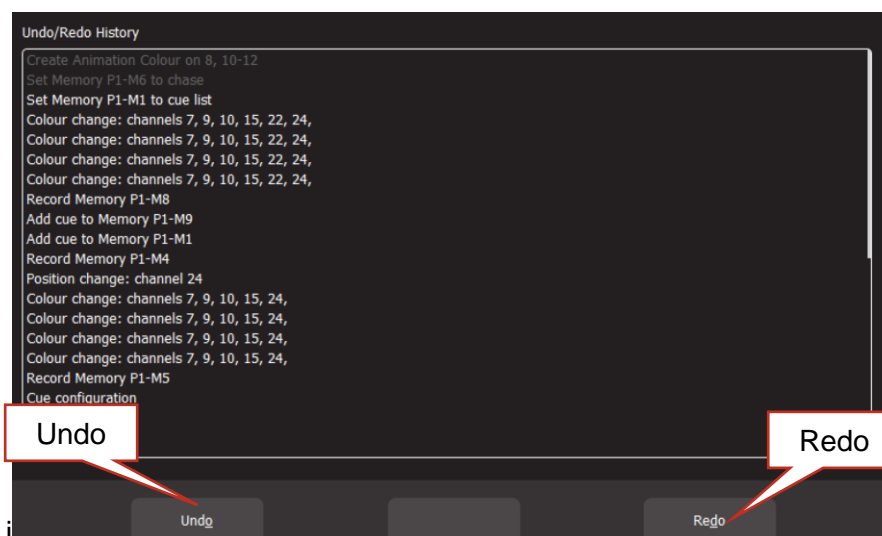

- Touch **Undo** to undo an action and step down the list.
- Touch **Redo** to redo an action and step up the list

Actions that have been undone turn grey.

This enables you to retract or reinstate programming at any point of plotting a show.

Press [Back] or press when finished.

*Note: The undo list is automatically cleared whenever you save your show, start a new show, load an existing show or switch off the power.*

*Note: The “Undo” function is not available when editing “Rig View” (section 7), when using the “Fixture Editor” (section 1) or when deleting a memory (section 19.4).*

### 3.3 Reset

In the unlikely event that your Mantra Lite stops responding, you can reset it by pressing and HOLDING the following 3 buttons for 0.5 seconds.

[Back] + Undo + Help.

All settings and memories are retained.

## 4 Patching Fixtures

### 4.1 Overview

The output control signal from the Mantra Lite is known as DMX512-A. It is an international standard for controlling lighting equipment. Your lighting fixtures and dimmers have a DMX input and usually a DMX output so that you can connect multiple devices in a daisy chain fashion. You set an address on each fixture and use Mantra Lite to control each fixture based on its address. Each fixture will use a quantity of DMX channels to control its different functions as listed in its specifications. The address that you choose for each fixture must allow for the addresses used by other fixtures so that no overlaps exist. For example, fixture 1 is set to address 001 and this fixture uses 4 DMX channels. Fixture 2 must be set to address 5 (or higher).

The DMX signal is output on the 5 pin XLR connector on the rear of the Mantra Lite. Each optional wing also has a DMX output. The optional QX1 node (USB to DMX adaptor) provides an additional DMX output.

Fixtures can also be controlled using either “ArtNet” or “sACN” protocols via the network connector. See section 4.12 for details.

Mantra Lite includes a fully integrated fixture library of over 5500 fixtures (most with multiple operating modes) supplied by Carallon, an independent supplier of fixture libraries. The fixture library contains a version number that is displayed in the “About” screen. From the “Home” screen touch **Tools, Setup, System Settings, About**.

If you do encounter a fixture that is not in the library you have two choices:

1. A fixture request service is available via the LSC web page. This process takes at least one month from the date of request.
2. The inbuilt Fixture Editor allows you to quickly create a template for a new fixture. See section 1.

In the Patch menu you tell Mantra Lite the manufacturer/model and DMX address of each of fixture it is controlling. You choose a fixture number (1 to 24) (yellow fader and button) then patch the fixture to that number as described below. Mantra Lite then loads a “template” for that manufacturer/model of fixture from its fixture library. The template tells Mantra Lite how to control that fixture.

The yellow fader of the fixture number that you select now controls the intensity and the touch screen provides the correct controls for that fixture via Apps. For example, if the fixture is a multi-coloured LED, Mantra Lite provides a colour picker App to control the colour and the yellow fader will control its intensity. If the fixture has pan and tilt capabilities Mantra Lite provides a position control App to control the position.

Up to 2 wings can be connected to a Mantra Lite console.

- Connecting a Mantra Wing provides control of an additional 12 lighting fixtures (25-36) as well as a second DMX512 universe (U2) output.
- Connecting a second Mantra Wing provides control of an additional 12 fixtures (37-48) as well as a third DMX512 universe (U3) output.

*Note: Early versions (v1.00 thru v1.37) of the Mantra Lite did not use the Carallon fixture library. Shows that were created with the original library will not work in the current Mantra Lite software. A warning message will appear when a show that contains old fixtures is loaded, asking you to repatch the fixtures using the new library. Instructions for this task are available via this weblink.*

*<https://www.lsccontrol.com.au/documents/Update%20MantraLite%20show/>*

*If this task is not done, then the show will not load in current and future software versions.*

## 4.2 Patching a fixture

Identify the manufacturer and model of the fixture to be patched and set or note its DMX address.

From the “Home” screen touch **Tools, Setup, Patch**. All buttons below the yellow faders will flash to show that they are available fixture number choices.

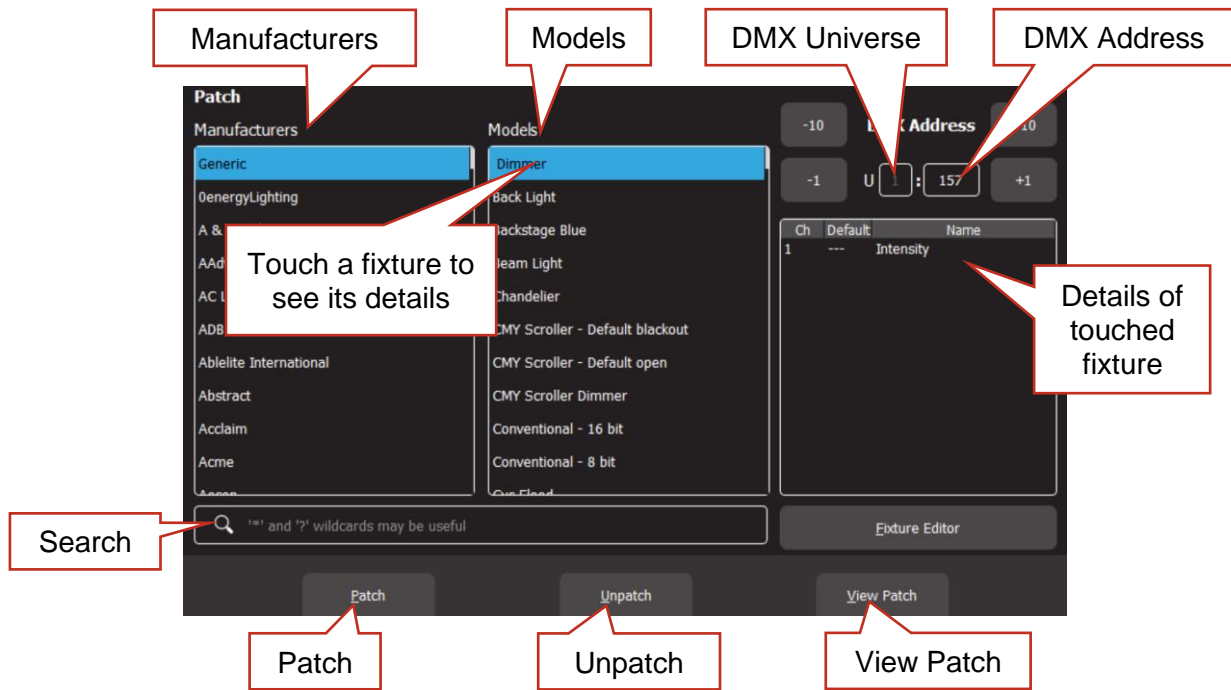

Find the Fixture Manufacturer by scrolling the left hand “Manufacturers” pane (or use the search function) and touch the **Manufacturer Name**.

*Hint: Dimmers and many LED fixtures can be found in the “Generic” manufacturers listing.*

Find the specific fixture Model by scrolling the middle “Models” pane (or use the search function) and touch the **Model Name**.

You can touch the “Search” icon and type in a manufacturer or model name using the pop-up keyboard. The symbol (\*) can be used as a substitute (wild card) for any string of characters in your search term. You can also use the symbol (?) as a substitute for one character.

When you touch a fixture model, the details of the DMX channels for that fixture (as contained in Mantra Lites fixture library) are shown on the right.

Set the universe to which the fixture is connected by touching the “U” box and using the **+10, +1, -10** and **-1** buttons.

- If you are only using the 5 pin DMX connector on the rear of the Mantra Lite then the Universe (U) should be set to 1.
- If you have optional wings or a QX1 USB to DMX adaptor you have access to multiple universes. The first plugged-in wing or node will be assigned to universe 2, the next to universe 3. The assigned universes are remembered as long as the wings or nodes are still plugged in when Mantra is switched on. To change the assigned universes, unplug

the wings or nodes and plug them in in the order that you require. A maximum of 3 DMX Universes (U1, U2, U3) are available.

- To map a universe (U1, U2, U3) to ArtNet or sACN, see section 4.12

Set the DMX address (to match the DMX address on the fixture you are patching) touching the “**DMX Address**” box using the **+10**, **+1**, **-10** and **-1** buttons.

Select a fixture number for the fixture to be patched by tapping one of the **flashing buttons** below the yellow faders. When a button is selected it stops flashing and remains lit. The button/fader that you choose will be used to control this fixture.

For example, press flashing yellow button 21 if you want the fixture’s intensity to be controlled by yellow fader 21 and its selection and flash function to be controlled by yellow button 21.

Touch **Patch** to make the connection.

If you now fade up the yellow fader that you selected (and the yellow master) the fixture will come on with white light. If it does not and you are certain that you have patched it correctly, check that the fixture is correctly connected via DMX cable, is switched on and is set to the correct DMX address and mode.

Repeat the above steps for each fixture to be patched.

When finished patching double tap  [Back].

*Hint: Save your show. See section 17. You might also consider saving a Default show. See section 19.5.*

The following sections describe advanced patching techniques. If all of your fixtures have now been patched there is no need to read these advanced techniques and you can go straight to section 8 and control your fixtures.

### 4.3 Patching Multiple Fixtures in One Operation

If you have multiple fixtures of the same type and mode that are set to contiguous DMX addresses you can speed up the patching process and patch them all in the one operation.

Use the same procedure as described above to select the manufacturer and model of fixture and the DMX address of the first fixture in the range.

Select a fixture number for the first fixture by tapping one of the **flashing buttons** below the yellow faders. Select a fixture number for the second fixture by tapping another yellow button. Continue to tap yellow buttons for each new fixture to be patched.

Alternately, to quickly select a continuous range of fixture numbers, press and **hold** the first yellow button number and tap the last yellow button number in the range.

Tap **Patch** and all of the selected fixtures will be patched in order to their respective yellow faders. The DMX address that you set for the first fixture is automatically incremented for each fixture according to the quantity of DMX slots used by each fixture.

For example. To quickly patch 6 identical RGB LED fixtures that each use 3 DMX slots, set the fixtures to contiguous DMX addresses of 1, 4, 7, 10, 13 and 16 respectively.

In the Patch menu set the DMX address to 1 (the first fixture’s address). To patch these 6 fixtures to yellow faders 1 through 6, press and **hold** the yellow **1** and tap yellow **6** then tap **Patch**.

When finished patching double tap  [Back].

#### 4.4 Multi-Patch. Patching Multiple Fixtures to the Same Fader

Multiple fixtures of the same type and mode but with different DMX addresses can be patched to the same yellow fader. This frees up yellow faders for other fixtures. Multi-patching is often done when multiple fixtures have a common purpose (such as a colour wash on the stage or all of the audience fixtures) and you want to control them all from the same fader.

*Note: You could set each fixture to the same DMX address and only make one patch to achieve the same result but sometimes you might not be able to access the fixtures to change their addresses or do not have permission to change their addresses so you need to use their existing addresses.*

Remember that each actual fixture must be the same type and be set to the same mode of operation.

To Multi-Patch, from the “Home” screen, touch **Tools, Setup, Patch**.

Use the same procedure as described in section 4.2 to select the type and model of the fixture then set the Universe (U) and DMX address to match the address of the first fixture to be patched.

Select a fixture number by tapping one of the **flashing buttons** below the yellow faders. The button/fader that you choose will be used to control all of the fixtures that you will patch to it.

Touch **Patch** to make the first connection. When a yellow fader has been patched to a fixture its button remains lit.

If you now fade up the yellow fader that you selected (and the yellow master) the fixture will come on.

Set the DMX address (top right-hand corner of the patch screen) to match the DMX address of the second fixture to be patched.

*Note: After you made the first patch, the DMX address automatically advanced to the next available DMX address, ready for another fixture to be patched. This might not be the address of your next fixture. Check and set the DMX address on the patch screen to match the DMX address of your next fixture.*

Press **Patch**. The second fixture will also come on. You now have two fixtures with different DMX addresses both being controlled by the one Yellow Fader.

Continue patching as many fixtures as required of the same type/mode/settings to the same yellow fader by setting the DMX address on the patch screen to match each fixture and pressing **Patch**.

When finished patching double tap  [Back].

To un-patch a fixture from a multi-patch see section 4.8

#### 4.5 Patching Compound Fixtures

A “compound” fixture is a fixture that contains multiple fixtures within the one fixture. Compound fixtures are also known as “Multi-Cell” fixtures.

For example, many RGB (Red, Green, Blue) LED strips are compound fixtures because they have multiple RGB cells within the one fixture. The fixture has a menu that allows you to select

different “modes” of operation. A simple mode might provide 3 control channels (RGB) that control the entire fixture. Other modes might allow you to divide the fixture into 3 sections and use 9 channels to control the RGB of each section. The most complex mode might allow you to individually control every pixel.

Complex modes use a lot of DMX channels and can be difficult to program. Compound fixtures usually also have modes that allow you to control effects that are built into the fixture such as pixel mapping effects, colour pulsing or chase effects. These modes use some of the DMX channels to control those effects and this makes the fixtures much easier to program.

LSC recommends that when patching compound fixtures, you select a mode that uses the least amount of channels but includes channels that control the built-in effects.

For example, a Chauvet DJ COLORband © LED strip fixture has multiple modes available:

- 3 channel mode has RGB channels for the whole fixture.
- 7 channel mode has RGB channels for the whole fixture plus channels for colour effects, speed, strobe, pulse/snap/fade and intensity.
- 12 channel mode splits the fixture into 4 sub-fixtures with RGB for each sub-fixture.
- 24 channel mode splits the fixture into 8 sub-fixtures with RGB for each sub-fixture.

In this case LSC recommends patching the fixture in 7 channel mode and utilising the in-built effects of the fixture. This will allow you to create complex effects in a fraction of the time than when operating in the other modes.

#### 4.6 View Patch

If you want to see and check all of the patches you have made from the Patch menu touch **View Patch**.

If you touch a fixture in the “Current Patch Information” pane on the left side of the screen, the details of the channels for that fixture are shown in the “Fixture” pane on the right side. For a description of “Home” values see section 4.10.

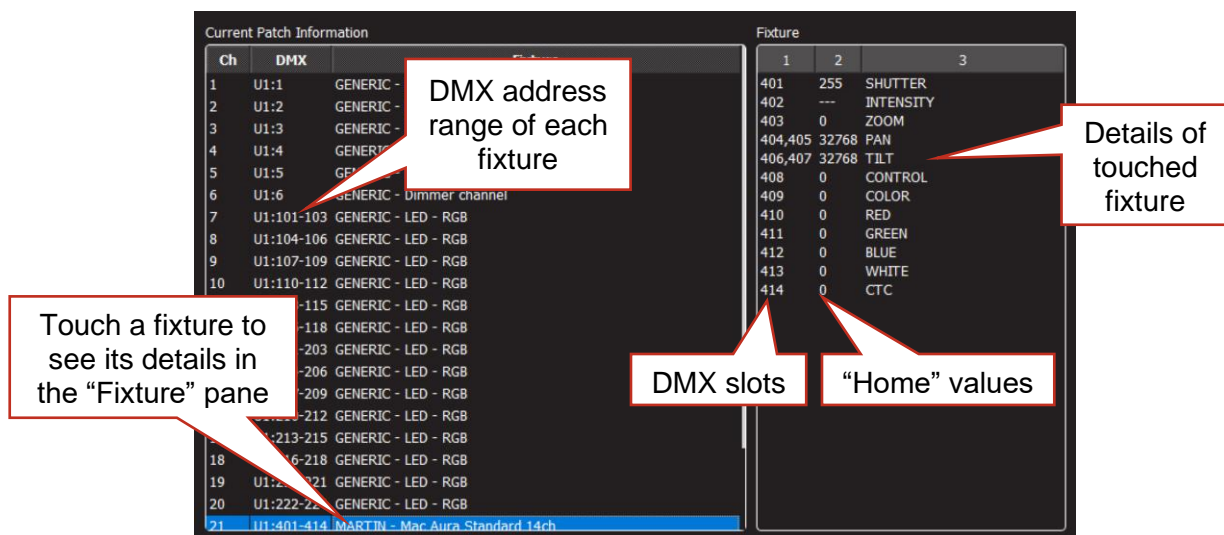

#### View Patch

To return to the Patch menu, tap [Back].

*Hint:* You can view the DMX output levels on each universe. From the home screen touch **Tools, Setup Universes, View DMX**. See section 4.13

#### 4.7 Un-Patching a Fixture(s)

From the “Home” screen touch **Tools/Setup/Patch**.

All buttons below the yellow faders will flash to show that they are available fixture number choices. Press a fixture number button to select it. Multiple fixture numbers can be selected. Selected fixture numbers are lit.

Touch **Unpatch**.

When finished, double tap  [Back].

#### 4.8 Un-patch a Multi-Patched Fixture

Multiple fixtures of the same type and mode but with different DMX addresses can be patched to the same yellow fader as described above. You can un-patch individual fixtures from a multi-patch or un-patch all fixtures in the multi-patch.

From the “Home” screen touch **Tools, Setup, Patch**.

All buttons below the yellow faders will flash to show that they are available fixture number choices. Press the fixture number button of the multi-patch to select it. The selected fixture number is lit. Touch **Unpatch**.

The screen shows with a list of fixtures patched to the selected yellow fader. The centre of the screen shows a list of the fixtures in the multi-patch with their Universe and DMX address range.

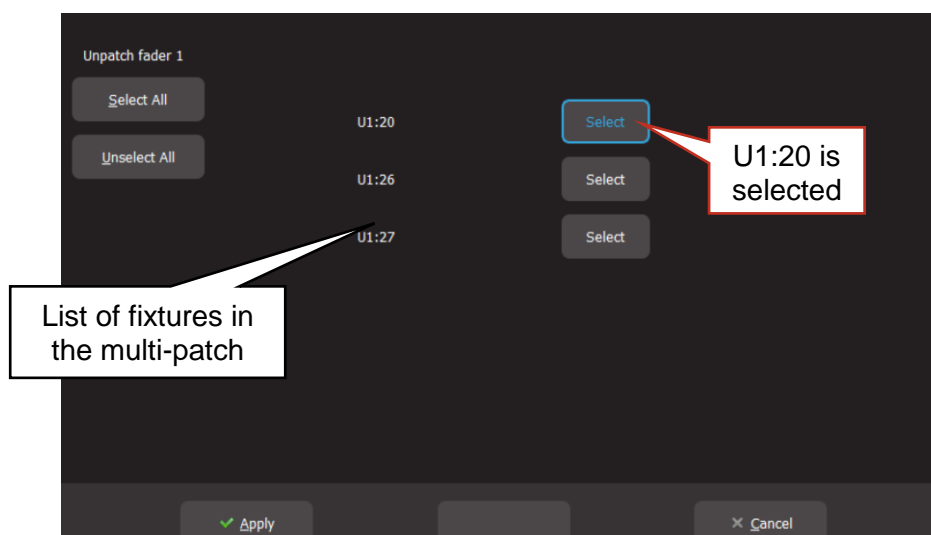

Touch the **Select** buttons of the fixture(s) that you wish to remove from the multi-patch. You can also use **Select All** or **Unselect All**. Touch **Apply** and the selected fixtures will be unpatched.

When finished, double tap  [Back].

***Note:** Multiple fixture numbers can be selected when un-patching. If multiple fixture numbers are selected and some are multi-patched you will be shown the following warning when you touch **Unpatch**:*

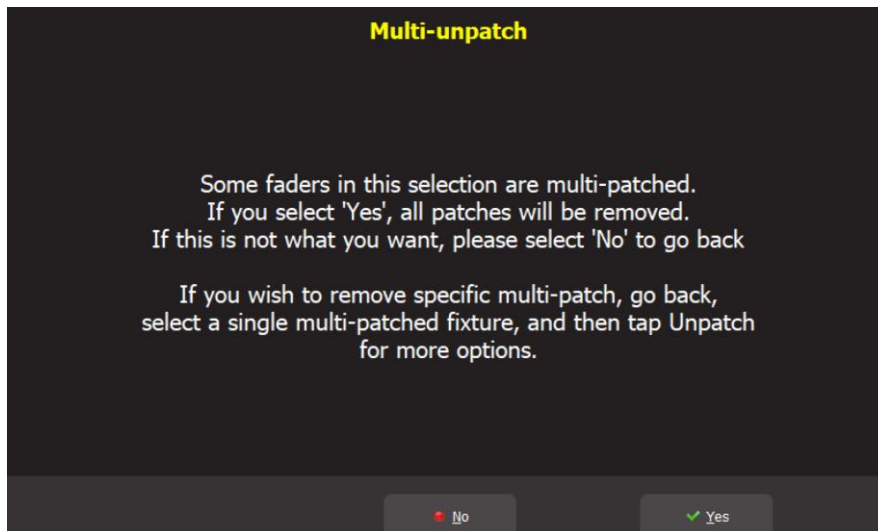

Touch **No** then select a single multi-patched fixture number and follow the instructions above.

#### 4.9 Save Patch

When you save a show, the patch is saved as part of that show. See section 17.

If the patch you have created is to be used on a regular basis such as in a permanent installation or in a touring show that always uses the same lighting rig then you should save it as the "default show". See section 19.5.

#### 4.10 Home Values

When you "Clear" a fixture (see section 8.9), if the fixture has a colour mixing function (RGB or CMY) Mantra Lite will set its colour to white and if it has a movement function it will centre the pan and tilt. These values are hard coded in the Mantra Lite software. All other attributes of the fixture will be set to their "home" values that are listed in their fixture template. You can see these values in the "View Patch" screen (above). Typically, these values will set a colour wheel to clear, gobo wheel to open, shutter to open etcetera so that the fixture outputs an open white beam.

#### 4.11 Fixture Editor

If you have a new fixture and it is not listed in the Mantra Lite fixture library you can create a template for it. You can also use the Fixture editor to edit an existing fixture template. See section 21 for details.

## 4.12 Universes

From the home screen touch **Tools, Setup, Universes**.

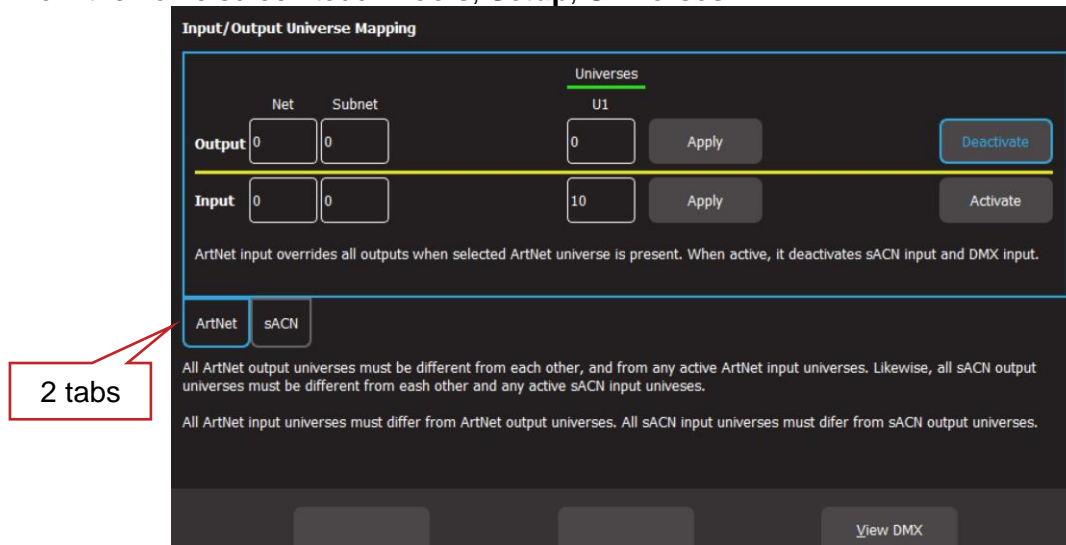

### Input/Output Universe Mapping (No Wings or QX1 Nodes connected)

The “Input/Output Universe Mapping” screen has the following functions:

- Set the universes (U1, U2, U3) for sACN output and for ArtNet output
- Activate/deactivate sACN output and ArtNet output
- Select the universes for sACN input and ArtNet input
- Activate/deactivate the sACN or ArtNet input that can override the output
- View the DMX output levels on each Universe

There are 2 tabs that can be selected, **ArtNet** and **sACN** and each have settings for “Output” and “Input” as described below.

*Note: Universe 2 (U2) is only available when one wing or a QX1 node is connected and Universe 3 (U3) is only available when either two wings or one wing and a QX1 node are connected.*

#### 4.12.1 sACN and ArtNet Output Rules

Mantra Lite can transmit its DMX output as DMX512, sACN and ArtNet. The patch screen (see section 4.1) allows you to patch each fixture to U1 (Universe 1). If an optional wing or QX1 node (USB to DMX adaptor) is connected you can also patch fixtures to U2 (Universe 2). If a second wing or QX1 node is connected you can also patch fixtures to U3 (Universe 3).

The “Universes” screen allows you to map the U1, U2 and U3 outputs of the patch screen to any sACN and ArtNet universes that you select.

The following rules apply when mapping sACN and ArtNet.

- All sACN output universes must be different from each other and from any active sACN input universes.
- All ArtNet output universes must be different from each other and from any active ArtNet input universes.
- All sACN input universes must differ from sACN output universes.
- All ArtNet input universes must differ from ArtNet output universes.

### 4.12.2 ArtNet Output

ArtNet is a streaming protocol to transport multiple DMX universes over an Ethernet cable/network. Mantra Lite can transmit ArtNet from the Ethernet connector. Mantra Lite supports Art-Net v4 which is configured as 128 Nets (0-127) each with 16 Subnets (0-15), each containing 16 Universes (0-15).

From the home screen touch **Tools, Setup, Universes**, touch the **ArtNet** tab.

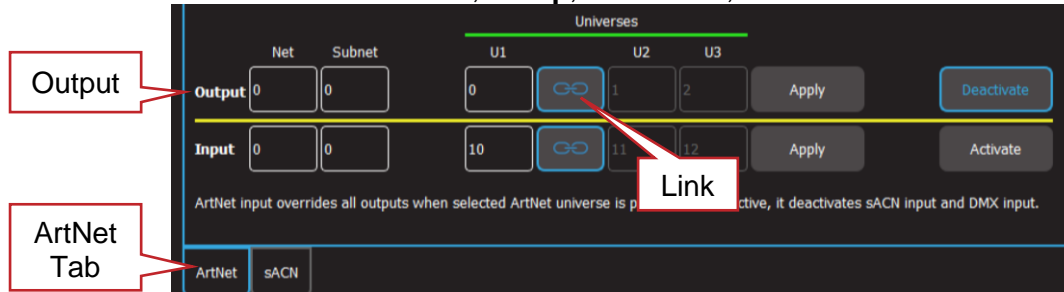

#### ArtNet Output (Two Wings or One Wing and a QX1 Node connected)

*Note: The U2 box only appears if a wing or a QX1 node is connected to the Mantra Lite. The U3 box only appears if two wings or one wing and a QX1 node are connected.*

Enter the Output “Net” and “Subnet” in their respective boxes.

- In the Output “U1” box, enter the number of the ArtNet universe that is to be mapped to the fixtures that have been patched to U1 in the Patch screen
- In the Output “U2” box, enter the number of the ArtNet universe that is to be mapped to the fixtures that have been patched to U2 in the Patch screen.
- In the Output “U3” box, enter the number of the ArtNet universe that is to be mapped to the fixtures that have been patched to U3 in the Patch screen.

Touching the “Link” symbol between the U1 and U2 boxes activates it (its border turns blue) causing U2 to be automatically set to be the 1 higher than U1 and U3 to be automatically set to be the 2 higher than U1.

Touch **Apply**. To output ArtNet on the ethernet connector touch **Activate**. To stop outputting ArtNet touch **Deactivate**.

*Note: When using Art-Net, Mantra Lite must have a valid IP address and NetMask entered in the “Network Settings” in order for Art-Net to work correctly. It is essential that the IP address is set to be compatible with the address on the device sending the Art-Net packets. Set the IP address according to the ArtNet recommendations using a 2.0.0.0. address range. See section 4.12.5 for ArtNet Input settings.*

### 4.12.3 sACN Output

sACN (Streaming ACN) is an informal name for the E1.31 streaming protocol to transport multiple DMX universes over an Ethernet cable/network. Mantra Lite can transmit sACN from the Ethernet connector.

sACN uses a priority system with the priority level set by the sACN transmitting device. If a device receives more than one sACN signal on the selected universe it will only respond to the signal with the highest priority setting. The default setting is 100. The priority can be set to any number in the range from 1 to 200, where 200 has the highest priority.

For example, two devices are transmitting sACN on Universe 1. One device has the default priority of 100 and the other has a priority of 150. The second stream will control the fixtures. If the second stream is not present, the first stream will take control. If both sACN streams have the same priority they will merge on an HTP (highest takes precedence) basis.

From the home screen touch **Tools, Setup, Universes**, touch the **sACN** tab.

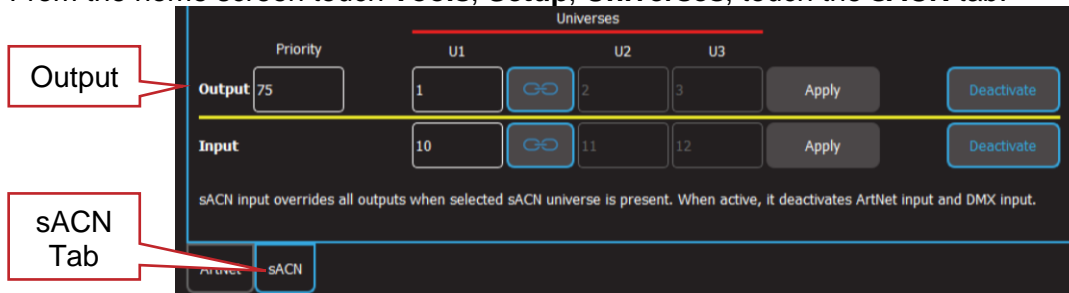

### **sACN Output (Two Wings or One Wing and a QX1 Node connected)**

*Note:* The U2 box only appears if a wing or a QX1 node is connected to the Mantra Lite. The U3 box only appears if two wings or one wing and a QX1 node are connected.

- In the Output “U1” box, enter the number of the sACN universe that is to be mapped to the fixtures that have been patched to U1 in the Patch screen
- In the Output “U2” box, enter the number of the sACN universe that is to be mapped to the fixtures that have been patched to U2 in the Patch screen
- In the Output “U3” box, enter the number of the sACN universe that is to be mapped to the fixtures that have been patched to U3 in the Patch screen.

Touching the “Link” symbol between the U1 and U2 boxes activates it (its border turns blue) causing U2 to be automatically set to be the 1 higher than U1 and U3 to be automatically set to be the 2 higher than U1.

If more than one device will be transmitting sACN on the same universes, enter an appropriate Priority number (see above). The priority level applies to all three sACN universes.

Touch **Apply**. To output sACN on the ethernet connector touch **Activate**. To stop outputting sACN touch **Deactivate**.

#### **4.12.4 Override (Art-Net or sACN Input)**

Mantra Lite can accept an Art-Net or sACN input signal from any other lighting console and can automatically override its own playback and retransmit the incoming signal (on the Mantra Lite output universes) when it detects the incoming signal.

Example 1.

Mantra Lite is outputting on DMX 1. Its input is set receive data in sACN universe 3. When Mantra Lite sees data on sACN universe 3, it re-transmits that data on DMX 1 (instead of its own data).

Example 2.

Mantra Lite is outputting on sACN Universe 1. Its input is set receive data in sACN universe 3. When Mantra Lite sees data on sACN universe 3, it re-transmits that data on sACN Universe 1 (instead of its own data).

A typical example is a theatre where the house lights and basic stage lights are connected to the Mantra Lite. During simple shows or meetings etcetera, these lights are controlled by the Mantra Lite. During complex stage shows, an expensive lighting console in the control booth is used to control the lighting. The control booth console is programmed with a patch that contains the same fixtures as in the Mantra Lite patch and an output of the control booth console is fed to the input of the Mantra Lite. When the Mantra Lite detects the signal from the other lighting console, it automatically hands over control of its fixtures to the control booth console.

When the control booth console is turned off (at the end of the show), the Mantra Lite detects that there is no input signal and the lighting control is automatically returned to the Mantra Lite

after a short delay. The delay time is dependent upon the protocol in use. The other lighting console that is to take control needs to have the same fixtures patched as in the Mantra Lite, except they will be patched to the sACN or ArtNet output that feeds the Mantra Lite. Only one input signal (sACN or ArtNet) can be selected at a time. Selecting a different input signal automatically disconnects the any previous selection.

#### 4.12.5 ArtNet Input

To configure the ArtNet Input to “override” the output, from the home screen touch **Tools, Setup, Universes**, touch the **ArtNet** tab.

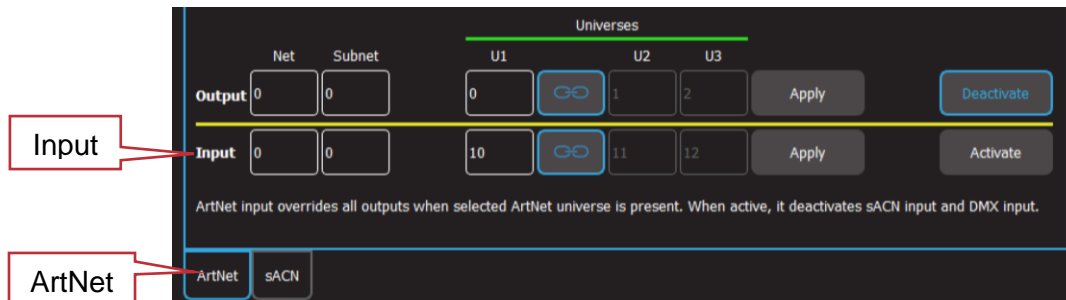

#### ArtNet Input (Two Wings or One Wing and a QX1 Node connected)

*Note:* The U2 box only appears if a wing or a QX1 node is connected to the Mantra Lite. The U3 box only appears if two wings or one wing and a QX1 node are connected.

Enter the Input “Net” and “Subnet” in their respective boxes.

- In the Input “U1” box, enter the number of the incoming ArtNet universe that is to be mapped to the fixtures patched to Mantra Lites U1 output
- In the Input “U2” box, enter the number of the incoming ArtNet universe that is to be mapped to the fixtures patched to Mantra Lites U2 output
- In the Input “U3” box, enter the number of the incoming ArtNet universe that is to be mapped to the fixtures patched to Mantra Lites U3 output

If the “Link” symbol between the U1 and U2 boxes is active (blue border) then U2 is automatically set to be the 1 higher than U1 and U3 is automatically set to be the 2 higher than U1.

Touch **Apply** then **Activate**.

#### 4.12.6 sACN Input

To configure the sACN Input to “override” the output, from the home screen touch **Tools, Setup, Universes**, touch the **sACN** tab.

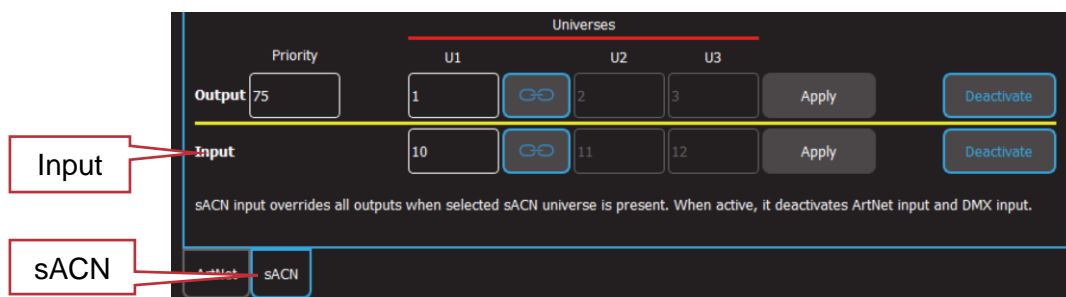

#### sACN Input (Two Wings or One Wing and a QX1 Node connected)

*Note:* The U2 box only appears if a wing or a QX1 node is connected to the Mantra Lite. The U3 box only appears if two wings or one wing and a QX1 node are connected.

- In the Input “U1” box, enter the number of the incoming sACN universe that is to be mapped to the fixtures patched to Mantra Lites U1 output

- In the Input “U2” box, enter the number of the incoming sACN universe that is to be mapped to the fixtures patched to Mantra Lites U2 output
- In the Input “U3” box, enter the number of the incoming sACN universe that is to be mapped to the fixtures patched to Mantra Lites U3 output

Touch **Apply** then **Activate**.

*Note: “Override” mode can be completely disabled/enabled by a “Remote Trigger”. See section 16.4.1.*

### 4.13 View DMX Output

From the home screen touch **Tools, Setup, Universes, View DMX**.

The screen shows the DMX levels for all 512 DMX slots of the universe as selected by the tabs at the bottom of the screen. Universe 2 becomes available when one wing or QX1 node (USB to DMX adaptor) is connected. Universe 3 becomes available when either two wings or one wing and a QX1 node are connected.

DMX Slot Numbers

DMX Slot Numbers

**View DMX Output**

## 5 Front Panel

### 5.1 Overview

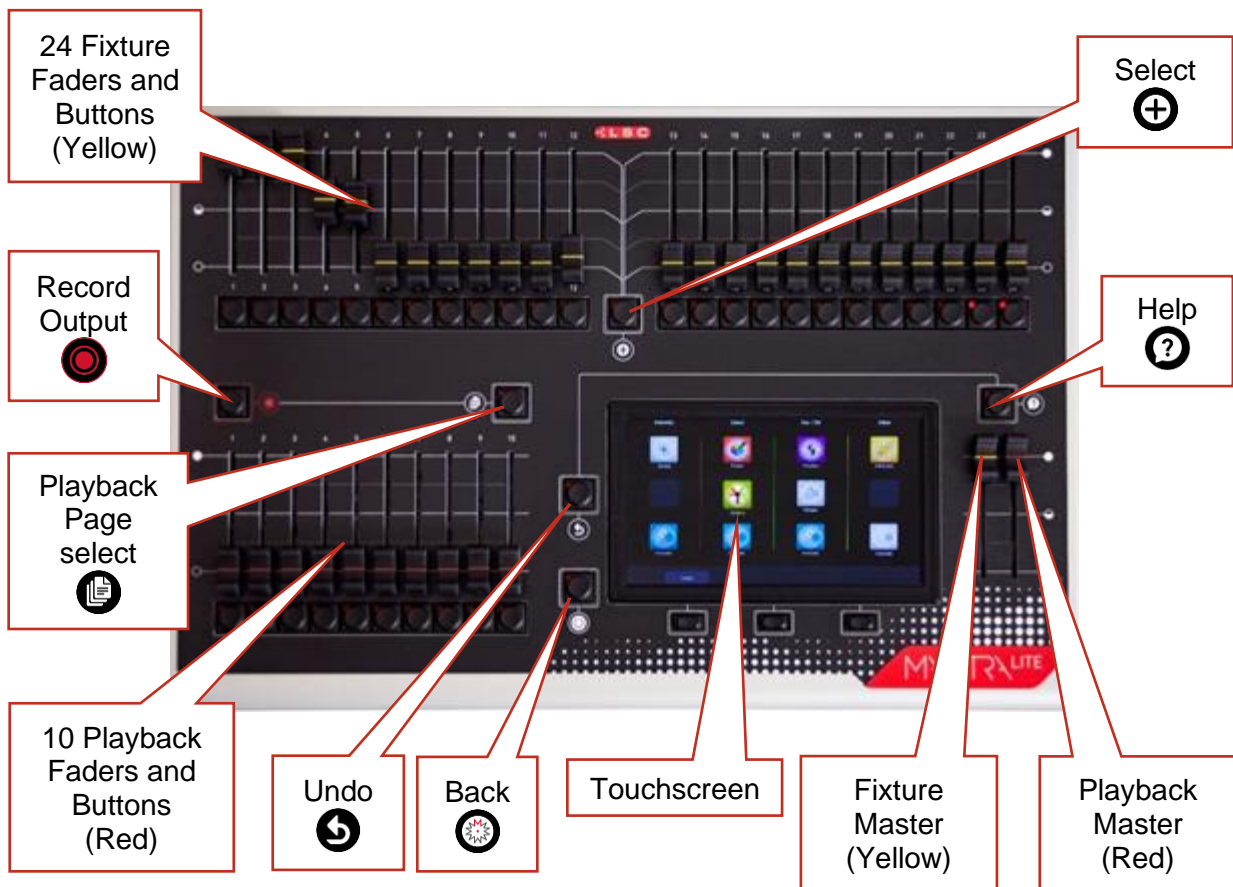

### 5.2 Basic Operation

Mantra Lite can control up to 24 lighting fixtures (up to 48 fixtures with optional wings). The 24 Yellow fixture faders control fixture intensity. Moving a fixture fader automatically selects that fixture allowing its other attributes such as colour or position to be controlled by Apps on the touchscreen (see section 6). Moving a fader to zero deselects the fixture. The [Select] button provides more fixture selection options.

The Yellow "Fixture Master" has overall intensity control of the yellow fixture faders.

The current output can be recorded into any of the Red playbacks by tapping [Record] then tapping a Red playback button of your choice [1-10]. Different looks can be recorded on different Red Playback faders or into a "Cue-list" on a single Red Playback fader so that you can easily change the entire look on stage by using the Red Playbacks. There are 10 red playback faders and 10 pages of memory giving a total of 100 memories.

- Repeated taps of the [Page] button will step through the 10 pages of memory.
- To switch directly to a page number HOLD [Page] and tap a Red playback button [1-10].

The Red "Playback Master" fader has overall **intensity** control of the Red playbacks.

## 6 Touch Screen

### 6.1 Overview

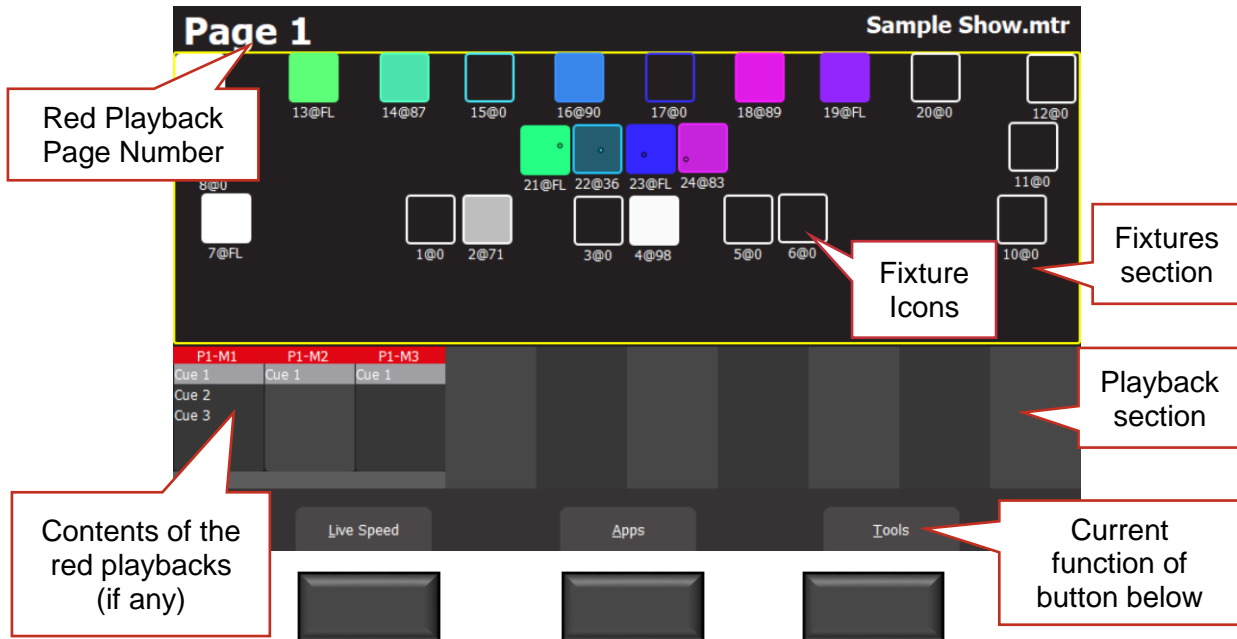

The top of the screen shows the current page number for the Red Playbacks. If one wing is connected its current page number is also shown in green text. If a second wing is connected its current page number is shown in blue text.

The 3 buttons below the touch screen have different functions for different screens. Their current function (if any) is shown on the screen above each button. You can either tap the button or touch the virtual button on the screen to operate them.

If the touch screen is not on the “Home” screen (as shown above), tapping the [Back] button steps back through the screens to the “Home” screen.

Double tapping [Back] quickly returns to the “Home” screen from any screen.

The “Home” screen is divided into two sections,

- The Fixtures section at the top (yellow border) has Fixture icons.
- The Playback section at the bottom has 10 Playback displayers (that show the contents of each playback when a recording has been made)

Some screens have sliders to adjust values. When you touch a slider, you can drag the slider and even let your finger drift off the slider as long as you keep your finger on the screen. If you touch the background, the slider will snap to where you touch.



***Hint:** All touchscreen events are triggered when you lift your finger from the screen. This allows you to slide to a different button or no button if you select the wrong item.*

From the “Home” screen, press **Apps** to open the “Apps” screen. Apps are used to control the attributes of selected fixtures. Move a yellow fader to automatically select that fixture. Use an App to adjust the attribute.

Touching and holding any fixture icon for 2 seconds opens “Rig View”. See section 7.

### 6.2 Fixture Icons

The top section of the “Home” screen has an icon for each of patched fixture.

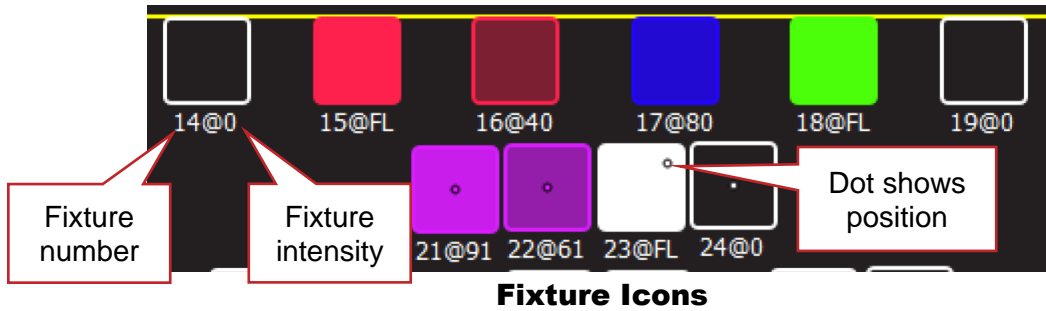

- Below each fixture icon is its fixture number and its intensity. For example, 21@91 means fixture 21 has an intensity of 91%. FL = Full intensity (100%).
- The body of each icon also shows the intensity of the fixture, dark to bright
- The body and border show the colour mixing (if the fixture has colour capability)
- A dot shows the position (if the fixture has a pan/tilt function)

*Note: The colour of the icon represents colours created by RGB (Red, Green, Blue) or CMY (Cyan, Magenta, Yellow) colour mixing in the fixture. Colours created by colour wheels or filters are not shown.*

### 6.3 Playback Displayers

The bottom section of the “Home” screen has playback displayers that show the contents of the 10 Red Playbacks. Playback displayers show the contents of a playback when a memory is recorded into a Page/Playback.

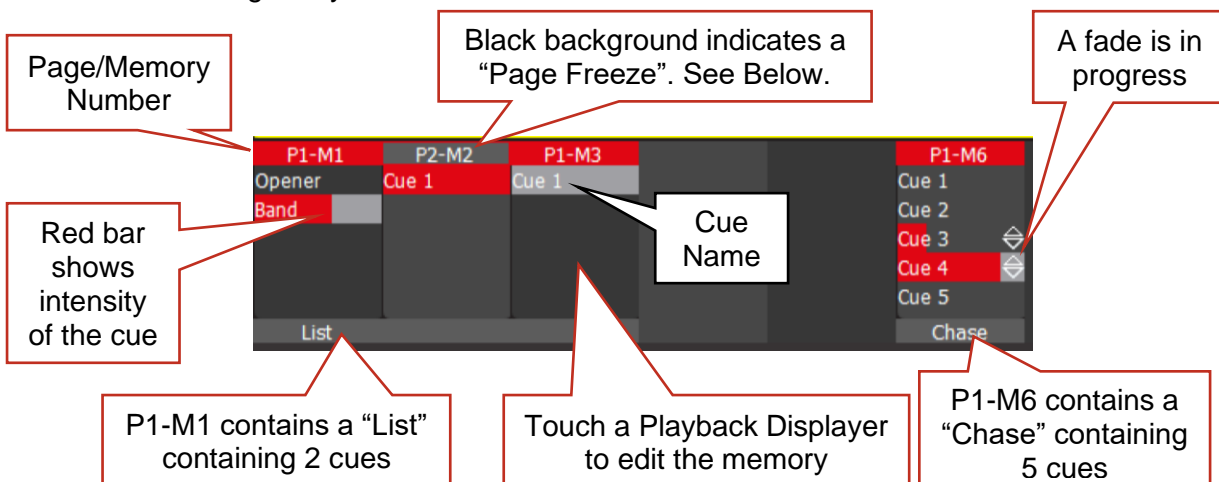

The top part of the playback displayer shows the memory number in the form of “P#” (Page number) and “M#” (Memory number). There are 10 Pages of memory available. The 10 Memory numbers relate to the 10 playback faders.

*Hint: You can change the name of each “Page/Memory number” and each “Cue number” and replace them with more descriptive names by “Editing” the memory. See section 13.*

A black background on the page/memory number at the top of the icon indicates that a "Page Freeze" has occurred. This means that this playback was active (faded up above zero) when the page number was changed and hence its memory is not from the "current" page. See section 11.2 for more information on "Memories" and section 12.5 for "Page Freeze".

If a wing is connected, press and hold its [View] button to momentarily view the contents of its Red playbacks. Double tap [View] to latch the display. Single tap to release.

Touching any playback displayer opens its "Edit Memory" screen,



Touch a cue to select/de-select it. Multiple cues can be selected.

Using this screen, you can,

- Select a single Cue then directly **Jump To** that cue using the recorded fade times. Useful if you have a long cue-list and you want to quickly playback a cue without stepping through all of the intermediate cues.
- Re-order the selected cue(s) using the  $\wedge$  or  $\vee$  buttons.
- "Include ICPB". When a memory is recorded it includes all of the Intensity, Colour, Position and Beam (I C P B) attribute groups. Touching an attribute group (**I C P B**) excludes that group from the playback. The selection applies to all cues in the cue-list. This is a very powerful function. See section 13.8.
- Change the "Fade In" and "Fade Out" times of the selected cues
- If the memory contains a cue-list you can set the "Link Time" of each cue (automatically plays the next cue).
- Re-name the Memory
- Re-name the selected cue
- Copy the selected cue
- Delete the selected cue
- Copy Memory (all cues in the list)
- Delete Memory (all cues in the list)
- Use the list as a chase or a cue-list

For more details on the functions above and also how to edit the contents (intensity, colour, position etcetera) of a cue see section 13.

*Hint:* You can also record a cue to a playback by pressing [Record] then tapping that playback's displayer. See section 11.3.

## 7 Rig View

### 7.1 Overview

The fixture icons on the “Home” screen can be arranged geographically so that they are positioned on the screen in a similar fashion to their position in your rig or stage. This can assist you in quickly identifying fixtures.

### 7.2 Arranging Icons

To arrange the icons, tap and HOLD any of the fixture icons for 2 seconds. A yellow flashing dotted box appears around the icons. Whilst the yellow box is flashing you can drag and drop individual fixture icons to position them on screen. You can also change the size of the icons or reset to the default positions.

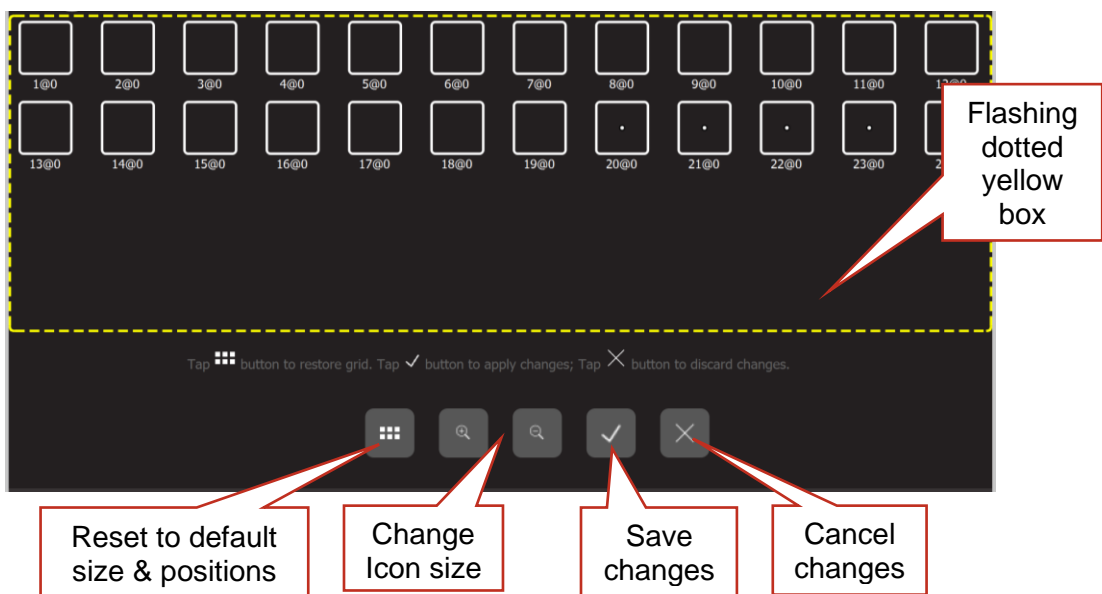

Touch to save your layout and exit.

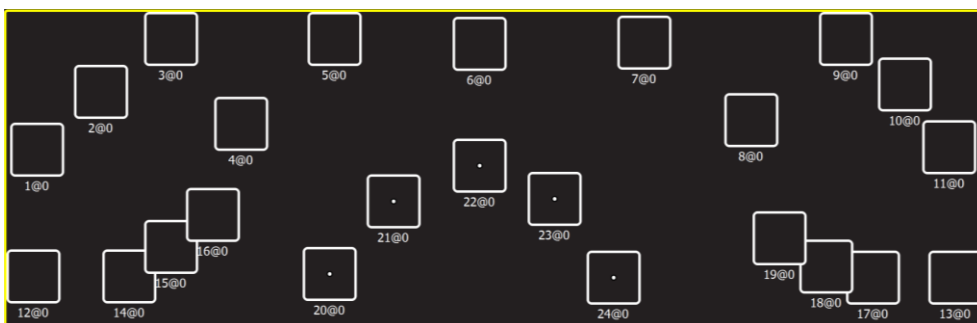

**Example of Icons re-positioned to match actual rig**

## 8 Controlling Fixtures

### 8.1 Intensity

The 24 (yellow) fixture faders (under the overall control of the yellow fixture master) control the intensity of the fixtures that are patched to them. To see the output of a fixture:

- Fade up the Yellow Master
- Fade up a fixture fader to set its Intensity

See also “Flash”, section 15.

### 8.2 Fixture Attributes

Mantra Lite uses “Apps” on the touch screen to control the attributes (colour, pan/tilt, shutter etcetera) of selected fixtures. From the “Home” screen, open the “Apps” screen by touching **Apps** or pressing the hard button below it.

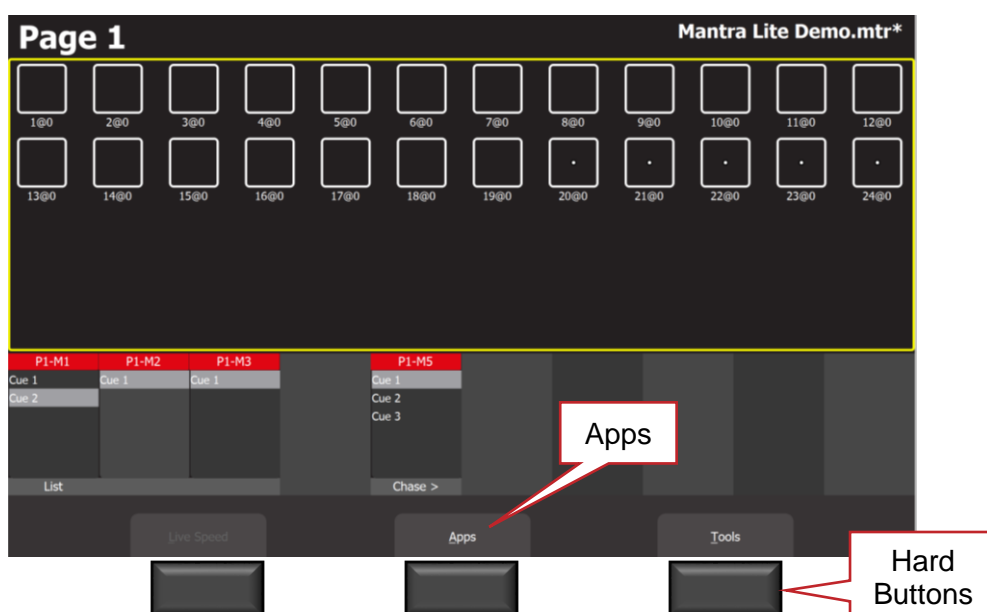

**“Home” Screen**

The Apps screen opens:

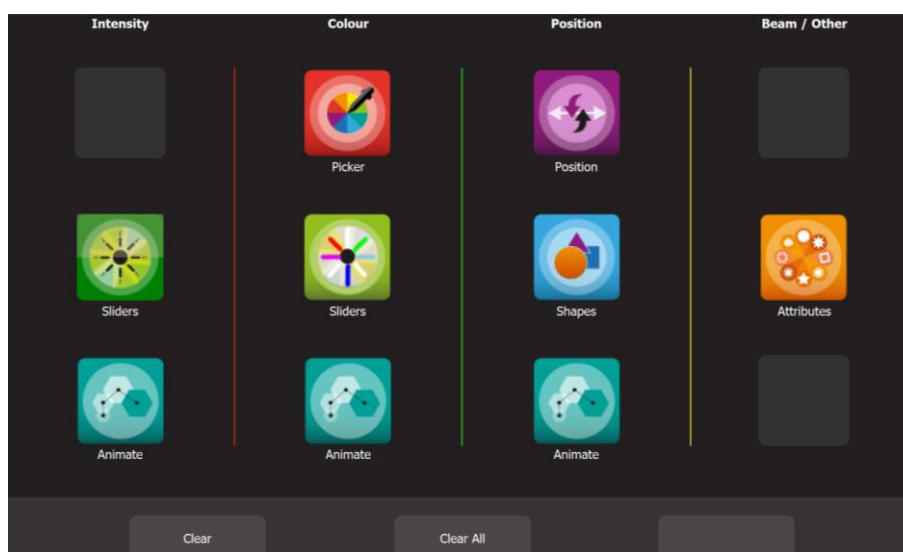

**Apps Screen**

Touch the App icon for the type of attribute that you want to control then select the fixture(s) to be controlled. Apps are arranged in 4 attribute columns. Each column has Apps for their type of attribute.

Animate Apps are described in section 9.

Shapes Apps are described in section 10.

### 8.2.1 Intensity Column

The Intensity “Sliders” app allows you to control the intensity of multiple (sub) fixtures within the one fixture. See section 8.5.1

The Intensity “Animate” app allows you to create intensity chasses and patterns. See section 9.

### 8.2.2 Colour Column

The “Picker” apps allow you to control the colour of selected fixtures and to “fan” colours across multiple fixtures. See section 8.6.1 for more details.

The “Sliders” apps allow provides individual sliders for all colours for selected fixtures. See section 8.6.2 for more details.

The “Animate” app allows you to create colour chasses and patterns.

### 8.2.3 Position Column

The “Position” app allows you to control the pan and tilt position of selected fixtures and to “fan” positions across multiple fixtures. See section 8.7 for more details

The “Shapes” app provides a quick and simple way of creating continuously moving positions.

The “Animate” app allows you to create moving beam effects.

See section 8.7 for more details.

### 8.2.4 Beam / Other Column

The “Attributes” app allows you to control all beam attributes such as “Gobo”, “Colour Wheel”, “Shutter” etcetera plus any other attributes of the selected fixture. See section 8.8 for more details.

## 8.3 Selecting Fixtures

When you use an App, you need to select the fixtures that you want to control with that App. Fixtures that have attributes that can be controlled by the selected App will flash their buttons indicating that they are available for selection.

For example, if you select a “Pan/Tilt” App, only fixtures with Pan/Tilt attributes will flash.

There are several methods of selecting fixtures:

- Move a yellow fader to automatically select that fixture. Move the fader to zero to de-select it. Move multiple yellow faders to select multiple fixtures
- Tap the button below a yellow fader to select that fixture. Tap again to deselect it. Multiple fixtures can be selected
- To quickly select a range of fixtures, hold the first button and tap the last button in the range. This works in either direction, low number to high number or high number to low number
- Press the  [Select] button. See below

When a fixture is selected its button is lit.

*Note: When you select multiple fixtures, the order in which you select the fixtures is used by Mantra Lite when you fan colours or positions and in animations and shapes. You can change the look of a fan, animation or shape by changing the selection order.*

To use any previous selections, press the  [Select] button (located between the yellow faders). The “Selection” screen opens,

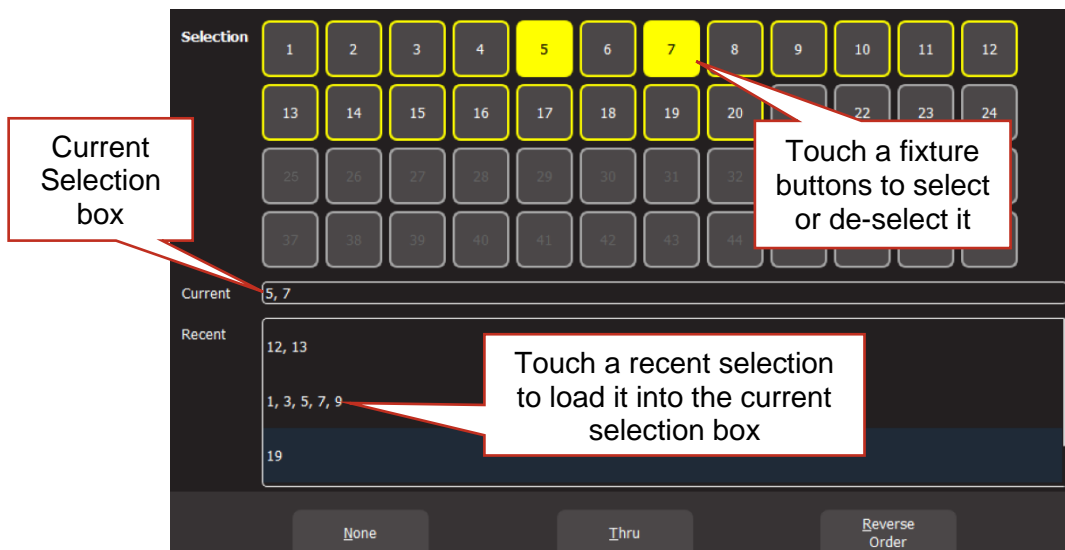

### Select Screen

The “Selection” area (the top half of the screen) shows all the possible fixture numbers.

- Patched fixture numbers have a yellow border
- Un-patched fixture numbers have a grey border
- Fixture numbers 25 to 36 are only available if one wing is connected
- Fixture numbers 37 to 48 are only available if a second wing is connected
- Selected fixtures have a yellow background

You can touch the fixture buttons to select or de-select them. To select a range of fixtures, touch the first fixture in the range then touch **Thru** then touch the last fixture in the range.

The “Current” area (in the middle of the screen) shows the current selection, in the order in which they were selected.

***Hint:** When you select multiple fixtures, the order in which you select the fixtures is used by Mantra Lite when you fan colours or positions and in animations and shapes. You can change the look of a fan, animation or shape by changing the selection order.*

The “Recent” area (the bottom half of the screen) shows a list of recent selections. Swipe down to see more (if available).

- To use a recent selection, touch that selection to load it into the current box
- To reverse the current selection order touch **Reverse Order**.
- To clear the current selection touch **None**.

Once a previous selection is selected you can still use the faders or buttons to modify the selection as described above.

***Hint:** If you select multiple fixtures by pushing up their faders at the same time you might get a random selection order. You can always check the current order by tapping  [Select] and then re-order the selection using the selection methods described above.*

***Note:** When using Apps to control fixtures, you can only select fixtures that have attributes that can be controlled by that App. For example, if you use the colour App you cannot select a dimmer because it does not have a colour attribute.*

## 8.4 Automatic Fixture De-select

When you open an App, fixtures that have attributes that can be controlled by that App flash their buttons indicating that they are available for selection. When you select fixtures, their buttons are lit. After you have used the App to change any attribute of the selected fixtures, selecting another fixture will cancel the previous selection and start a new selection process. This speeds up operations because you don't have to de-select fixtures once you have set their attributes. For example: Open the Colour Picker App and fade up fixtures 1 and 2. They are automatically selected. Pick a colour. Fade up fixture 3 and 4. This de-selects 1 and 2 and selects 3 and 4. Pick a colour for 3 and 4.

Automatic fixture de-select can be overridden by holding the  [Select] button whilst selecting additional fixtures. This allows you to easily add fixtures to those that you have already adjusted.

## 8.5 Controlling Intensity

Most fixtures have a single intensity channel and it is always controlled by the fixture's yellow fader. Some fixtures contain multiple (sub) fixtures within the one fixture and are sometimes known as "compound" or "multi-cell" fixtures. These are controlled from the "Intensity Sliders" App as described below.

### 8.5.1 Intensity Sliders App

If a fixture contains multiple (sub) fixtures within the one fixture, the individual sub fixture intensities are controlled by sliders in the "Intensity Sliders" app. From the "Home" screen, open the "Apps" page (described above) then touch the "Sliders" app icon in the "Intensity" column.

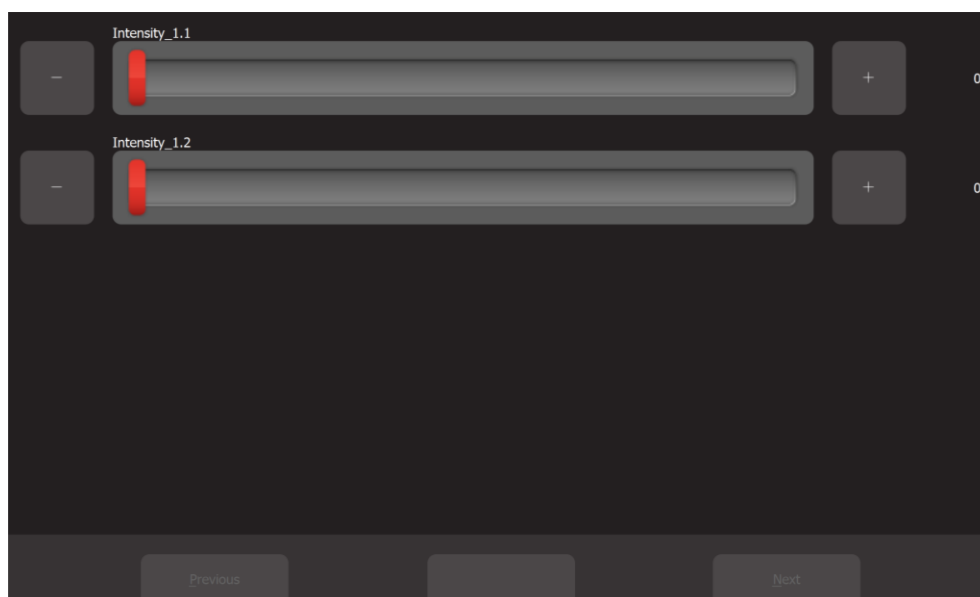

### Intensity Sliders

The yellow fader always acts as a master intensity over the individual sub fixture intensities.

## 8.6 Controlling Colour

### 8.6.1 Picker App

From the "Home" screen, open the "Apps" page (described above) then touch the colour Picker app icon. Fixtures that have colour attributes will flash their buttons. Select the fixtures (described above) then drag your finger to change the colour. The final colour is selected when

you lift your finger from the screen. The side of the colour picker app shows the recently selected colours (latest at the top). Touch any of the recent colours to re-use them.

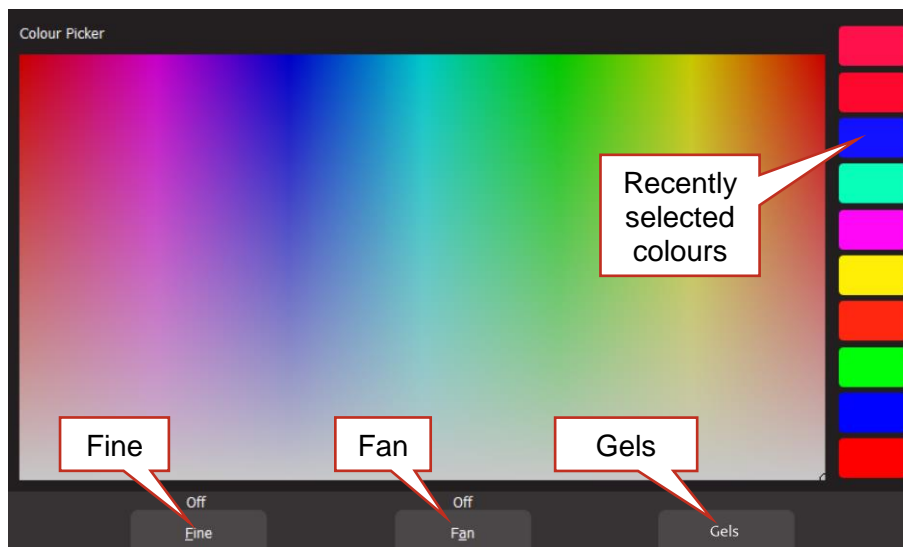

**Colour Picker**

**8.6.2 Fine**

Touching Fine provides finer control of colour. Touch again for normal control.

**8.6.3 Fan**

When multiple fixtures are selected you can fan their colours to create rainbow effects.

- Touching Fan selects “Directional” fanning. Tap to set the first colour then tap and drag to fan the colours across the selected fixtures. The first fixture in your selection has the colour where you first tapped the screen and the last fixture in your selection has the colour where you stopped dragging
- Touching Fan again selects “Symmetrical” fanning. Tap to set the first colour then tap and drag to fan the colours across the selected fixtures. The first and last fixtures in your selection have the colour where you first tapped the screen and your finish colour where you stopped dragging is in the centre of you fixture selection
- Touching Fan again turns fanning off

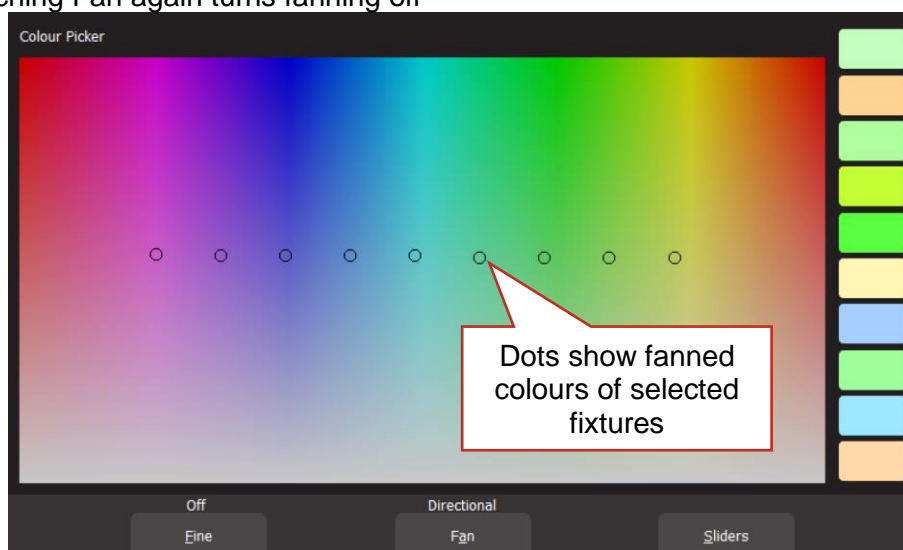

**Directional Fanning**

Your fixture selection order is used by the Fan App. Experiment with different orders of selection to get different colour effects. Previous selections can be re-used by tapping the [Select] button.

### 8.6.1 Gels

Gels is similar to the “Picker” app but has 100 commonly used colour gels to choose from.

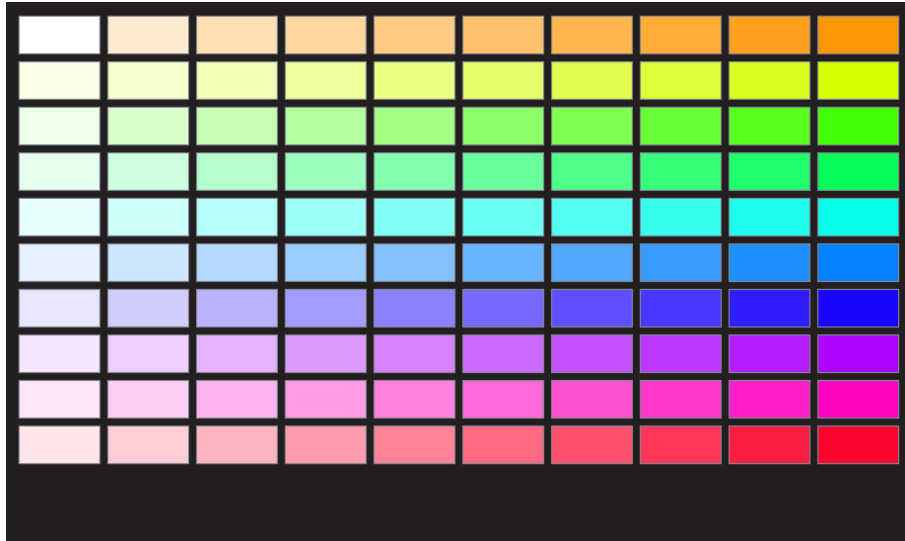

**Colour Gels**

Touch a colour to apply it to your selected fixtures.

### 8.6.2 Sliders

From the “Home” screen, open the “Apps” page (described above) then touch the colour Sliders app icon. Fixtures that have colour attributes will flash their buttons. Select the fixtures (described above) then use the individual colour sliders to control the selected fixture(s). Up to 5 attributes are displayed on a page. Touch **Next** to see more attributes (if available).

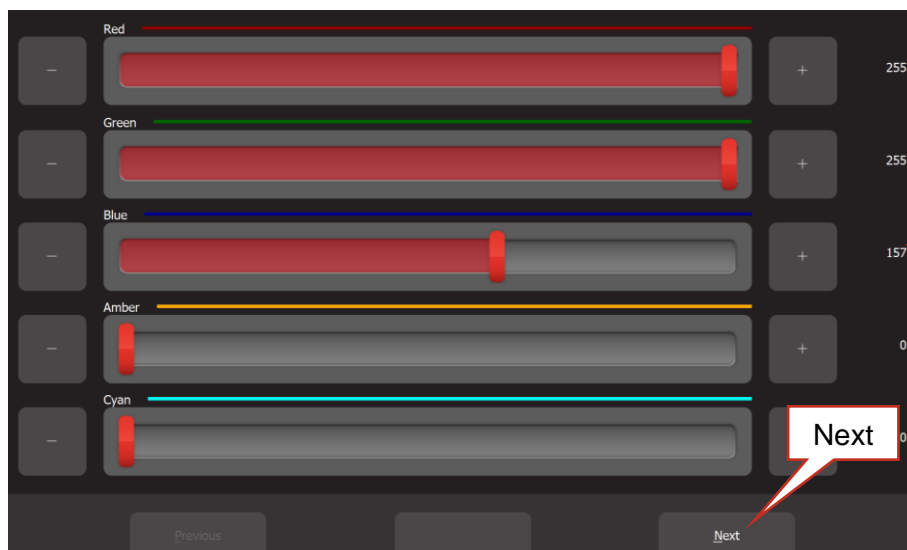

Decimal Value

Next

**Colour Sliders**

- + and – buttons are provided for small increments
- The decimal values of each slider are shown on the right

Some fixture attributes can be set to either “Fade” or to “Snap” to their recorded values. When you record a cue that includes the selected fixture(s), this setting will be included. When the cue is played back, attributes set to “Fade” will follow the movement of the red playback fader. Attributes set to “Snap” will go to their recorded value as soon as the red playback fader is raised above zero. To change a snapping attribute to “Fade” touch **Set to Fade**. To change a fading attribute to “Snap” touch **Set to Snap**.

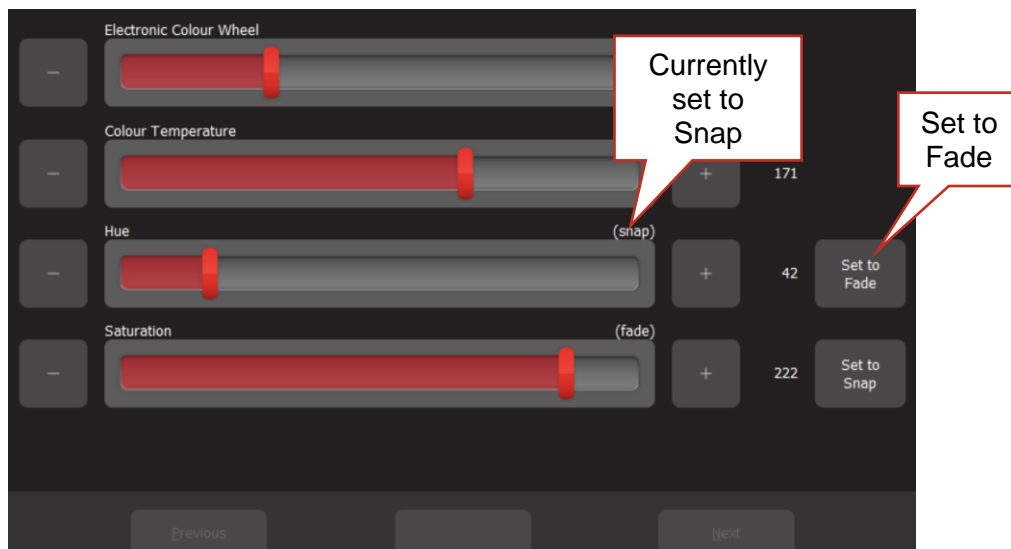

### 8.7 Controlling Position

From the “Home” screen, open the “Apps” page (described above) then touch the “Position” app. Fixtures that have Position (pan and tilt) attributes will flash their buttons. Select the fixtures (described above) then drag on the touch screen to move the position. You don’t have to touch the current position icon to move a fixture, you can touch and drag anywhere on the screen and the selected fixture(s) will follow your movements. You can also make fixtures move continuously in a shape or pattern. See section 10.

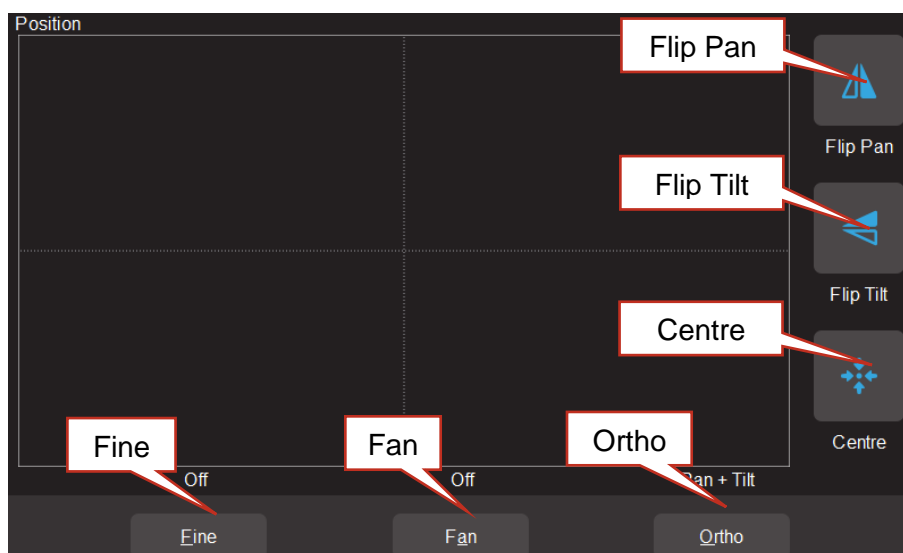

**Pan /Tilt Position**

#### 8.7.1 Flip Pan/Flip Tilt

Touching **Flip Pan** inverts the pan as you drag.

Touching **Flip Tilt** inverts the tilt as you drag. A blue border on the icon indicates “Flipped”. These settings are useful if the fixture movement is opposite to the movement on the touch screen.

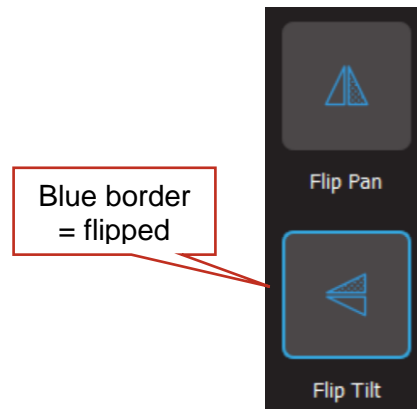

### 8.7.2 Centre

Touching **Centre** moves the selected fixtures to their centre position.

### 8.7.3 Fine Control

For finer control touch the **Fine** button. Touch again for normal control.

### 8.7.4 Ortho Control

Touches of **Ortho** cycles through, “Pan Only”, “Tilt Only” and “Pan + Tilt”. These settings are useful when making fine adjustments.

### 8.7.5 Fan

When multiple fixtures are selected you can fan their positions to achieve symmetrical patterns on stage.

- Touching Fan selects “Centred” fanning. Drag to fan the positions around the centre fixture.
- Touching Fan again selects “Directional” fanning. Drag to fan the positions around the first fixture in your selection.
- Touching Fan again selects “V-Shape” fanning. This pan works best when fixtures are already fanned into a line. Drag to pull the line of fixtures into a V shape.
- Touching Fan again turns fanning off.

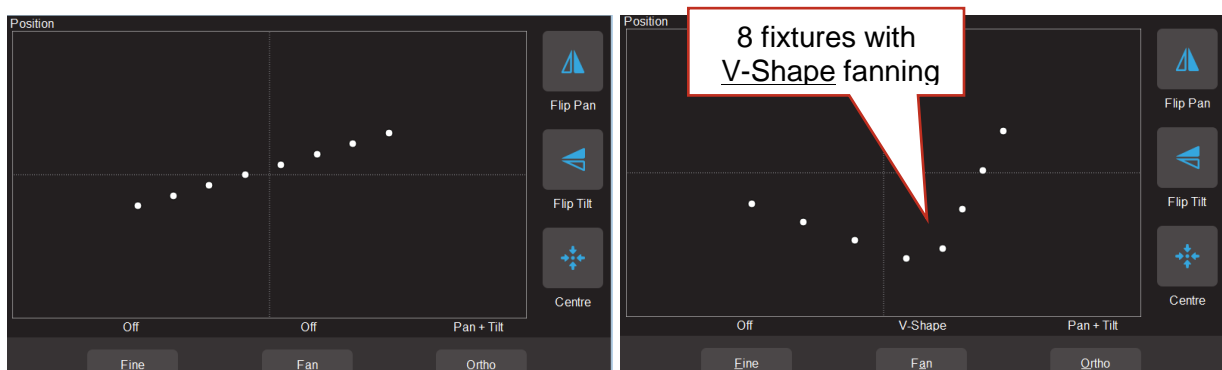

Your fixture selection order is used by the Fan App. Experiment with different orders of selection to get different shapes. Previous selections can be re-used by tapping the [Select] button.

## 8.8 Controlling Beam and Other Attributes

This app provides slider controls for all attributes not controlled by the Intensity, Colour or Position Apps. From the “Home” screen, open the “Apps” page (described above) then touch the “Attributes” app then select the fixture(s) to be controlled. The controls will vary depending upon the selected fixture. Typical attributes are colour wheels, gobo wheels, shutter and prisms. Up to 5 attributes are displayed on a page. Touch **Next** to see more attributes (if available).



### Typical “Other Attribute App”

All “Beam/Other” attributes can be set to either “Fade” or “Snap”. When you record a cue that includes the selected fixture(s), this setting will be included. When the cue is played back, attributes set to “Fade” will follow the movement of the red playback fader. Attributes set to “Snap” will go to their recorded value as soon as the red playback fader is raised above zero. To change a snapping attribute to “Fade” touch **Set to Fade**. To change a fading attribute to “Snap” touch **Set to Snap**.

## 8.9 Clearing Fixtures

When you use an App to change colour, position or beam fixture attributes, the settings for the fixtures are remembered in the “Live Memory” of the yellow fixture faders. When you record a cue, these settings are retained in the Live Memory allowing you to make further changes and record more cues.

When you use an App to create an animation or shape it is also remembered in the yellow fixture faders’ “Live Memory”. When you record a cue any animation or shape in the Live Memory is automatically cleared.

It is standard practice to clear the “Live Memory” settings (see “Clear All” below) and therefore restore fixture(s) to their default settings (open, white, centred beam) as well as delete any animations or shapes whenever you are starting to program a new lighting look. You can also choose to only clear selected fixtures or selected attributes and retain some live settings as described below.

### 8.9.1 Clear All

To clear all setting from the Live Memory, from the “Home” screen touch **Apps**, then from the Apps screen touch **Clear All**.

*Hint: It is a good idea to **Clear All** whenever you have any unexplained output from the Mantra Lite.*

### 8.9.2 Selective Clear



#### Apps Screen

From the “Apps” screen, touch **Clear**. The “Clear Live Memory” screen appears:

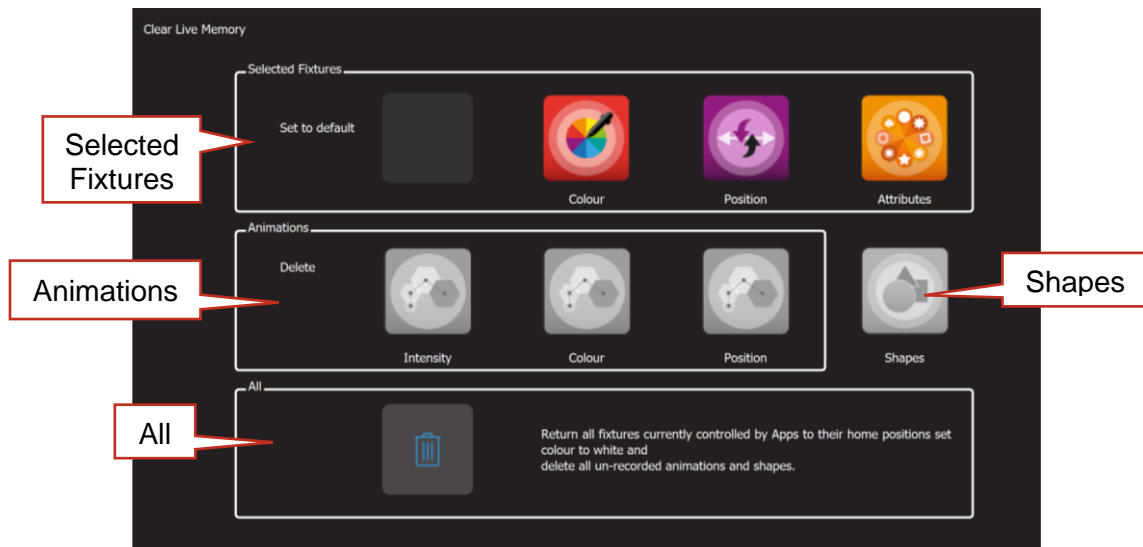

#### Clear Live Memory

Selected Fixtures can be set to their “Default” values of White, Centre and “Home” values. To clear a fixture(s), select the fixture(s) (see section 8.3) then touch the required Icon (**Colour**, **Position** or **Attributes**).

Animations can be selectively deleted by touching the required Icon, **Intensity**, **Colour** or **Position**.

Shapes can be deleted by touching the **Shapes** Icon

All. Touching the  (**trash can**) icon will set all fixtures to their default values (listed above) whether they are selected or not. It will also delete all animations and shapes running on the yellow faders. Recorded animations are not affected. This is the same as touching **Clear All** on the Apps screen.

## 9 Animate Apps

### 9.1 Overview

Animate Apps take the static output of Mantra Lite and bring it to life by providing a simple and intuitive way of creating moving patterns and colour or intensity chases.

Animations work with 2 or more selected fixtures and they shift the attribute values (such as intensity or colour or position) from one fixture to the next and loop the values of the last selected fixture back to the first. The shifting runs continuously forming a pattern or chase. There must be at least one different value amongst all of the selected fixtures (such as a different colour) so that you can see the different value being shifted from one fixture to the next.

There are Animate Apps for:

- Intensity.
- Colour.
- Pan/Tilt.

Multiple animations can be recorded in a single cue.

### 9.2 Creating an Animation

The basic steps to creating an animation are:

1. Program the output of Mantra Lite for the static look of the animation. Remember that there must be at least one different attribute value amongst all of the fixtures. For example, in a 4 fixture colour animation, 3 fixtures might be red and one blue or in a 3 fixture intensity chase one fixture might have intensity and the other 2 are faded down.
2. Open an Animation App (Intensity, Colour or Pan/Tilt), select all of the fixtures for the animation then touch **Create** and the animation runs.
3. You can adjust the animation controls if necessary, to set the speed, crossfade etcetera. See section 9.3.
4. To keep the animation for later playback, record it as a cue. See section 11.

Examples of intensity, colour and pan/tilt animations are described in section 9.4.

Multiple animations can be running simultaneously and all the animations that are running when a cue is recorded will be included in the cue.

***Note:** The order in which you select the fixtures is used by the animation app. You can get different animation patterns by experimenting with different selection orders. The selection order is shown in the animation app when you “create” the animation (see “Animation Controls” below). If you have created an animation and you want to change the selection order, touch **Delete**, select the new fixture order then touch **Create**.*

If you select fixtures by moving multiple faders at the same time you might get a random selection order however Mantra Lite will automatically attempt to arrange the fixtures in numerical order for you.

***Note:** If you create an animation then decide to Record the animation into a cue on a red fader, the recording process automatically clears that animation from the yellow faders. Therefore, if you want to keep the animation continuously running on the output you should fade up the red playback fader before tapping its button to make the recording.*

Fixture attributes such as colour or position are not cleared by recording a cue.

### 9.3 Animation Controls

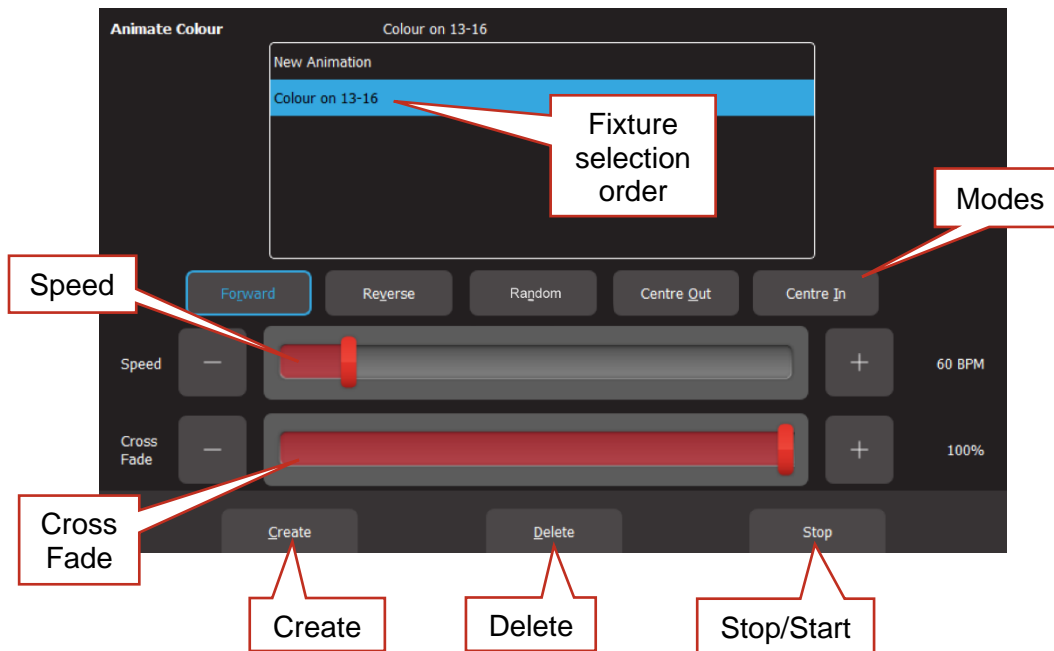

All animation Apps have Slider controls for:

- Speed in BPM (Beats Per Minute)
- Crossfade between steps (as a percentage of the speed).

For example, if the speed is set at 60 BPM (which is one step per second), then with crossfade set at 0% (that is, no fade), the animation will wait for one second, then snap to the next step. None (0%) of the available speed time will be used for crossfading.

If the crossfade is set to 50%, then the animation will perform a 0.5 second crossfade to the next step, wait for 0.5 seconds and then perform the next crossfade. That is, 50% of the time is used to perform a crossfade and 50% of the time is spent waiting before starting the next crossfade. If the crossfade is set to 100%, then the animation will use 100% of the time performing a crossfade to the next step. When the crossfade is complete, the next crossfade will commence immediately.

Animations can be run in the following modes. These choices will only be noticeable when 3 or more fixtures are in the animation.

- Forward or Reverse
- Random
- Centre Out or Centre In. These choices work best with an odd quantity of fixtures so that the pattern is symmetrical around the centre fixture. If you have an even number of fixtures there is no centre fixture because the centre is the gap between fixtures. You must therefore program a symmetrical static look with at least one different setting on both sides of centre.

You can also **Stop** and **Start** the animation.

*Note: Changing modes between Forward (or Reverse) and Centre In (or Centre Out) on a running animation can cause unexpected (and sometimes interesting) results depending upon the position of the animation pattern at the instant that you change modes. For consistent results you should Stop the animation, change modes then Start the animation again.*

### 9.4 Animation Examples

The following sections have examples of how to create intensity, colour and Pan/Tilt animations. All animations have the same controls available to vary the animation.

*Hint: It is a good idea to clear all fixtures before you start to create your first animation. From the “Home” screen touch **Apps, Clear All.***

If you already have an animation running that you want to retain, then only clear the type of attribute in the new animation. For example, if you have a colour animation running and you want to create a Pan/Tilt animation. From the “Home” screen touch **Apps, Clear, “Animations”, Position.**

### 9.4.1 Intensity Animation

Example 1:

To create a 4 fixture intensity animation with only one fixture on at a time (a chase) using fixtures 1 to 4:

- Use the fixture faders to create the static look of the animation on the output by fading up fixture 1 and fading down all other output.
- Open the “Intensity” **Animate** app.
- Select fixtures 1 through 4 by holding fixture [1] button and tapping fixture [4] button (or tap them individually in the order that you want them to animate).
- Touch **Create** and the animation runs as an intensity chase on fixtures 1 to 4.
- Use the controls described above to set the rate, crossfade, direction etcetera.

	Fixture 1	Fixture 2	Fixture 3	Fixture 4
Step 1		█	█	█
Step 2	█		█	█
Step 3	█	█		█
Step 4	█	█	█	
Step 1		█	█	█

Example 2:

To create a 6 fixture intensity animation with 5 fixtures on at a time using fixtures 1 to 6:

- Use the fixture faders to create the static look of the animation on the output by fading up fixtures 1, 2, 3, 4 and 5 and fading down all other output.
- Open the “Intensity” **Animate** app.
- Select fixtures 1 through 6 by holding fixture [1] button and tapping fixture [6] button (or tap them individually in the order that you want them to animate).
- Touch **Create** and the animation runs as an intensity chase on fixtures 1 to 6.
- Use the controls described above to set the rate, crossfade, direction etcetera.

	Fixture 1	Fixture 2	Fixture 3	Fixture 4	Fixture 5	Fixture 6
Step 1						█
Step 2	█					
Step 3		█				
Step 4			█			
Step 5				█		
Step 6					█	
Step 1						█

### 9.4.2 Colour Animations

Example 1:

To create a red/blue colour animation across fixtures 7 to 10:

- Fade down all output.

- Fade up fixtures 7, 8 and 9 then use the “Colour” Picker App (section 8.6) to set the fixtures to red.
- Fade up fixture 10 then use the “Colour Picker” App to set the fixture to blue.

You have now created the static look of the animation.

- Open the “Colour” **Animate** App.
- Select fixtures 7 through 10 by holding fixture [7] button and tapping fixture [10] button (or tap them individually in the order that you want them to animate).
- Touch **Create** and the colour animation runs.

Use the controls described above to set the rate, crossfade, direction etcetera.

	Fixture 7	Fixture 8	Fixture 9	Fixture 10
Step 1	Red	Red	Red	Blue
Step 2	Blue	Red	Red	Red
Step 3	Red	Blue	Red	Red
Step 4	Red	Red	Blue	Red
Step 1	Red	Red	Red	Blue

### Example 2:

To create a fanned colour animation across fixtures 13 to 20:

- Fade down all output.
- Fade up fixtures 13 to 20.
- Open the “Colour” Picker App and select “Symmetrical Fan” by touching Fan twice then drag to fan the colours across the selected fixtures.

You have now created the static look of the animation.

*Hint: Choosing “Symmetrical”, fans the colours around the centre fixture(s) so that the first and last fixtures have similar colours. This gives the animation a smooth colour transition from last fixture to the first fixture.*



- Open the “Colour” **Animate** App.
- Select fixtures 13 through 20 by holding fixture [13] button and tapping fixture [20] button.
- Touch **Create** and the fanned colours animate through the selected fixtures.
- Use the controls described above to set the rate, crossfade, direction etcetera.

### **9.4.3 Pan/Tilt Animations**

#### Example 1:

To create a Pan/Tilt animation across fixtures 21 to 24:

- Fade down all output.
- Open the “Pan/Tilt” **Position** App.
- Fade up fixture 21 and position it to the front of the stage.
- Fade up fixtures 22, 23 and 24 and position them to the back of the stage.

You have now created the static look of the animation.

- Open the “Pan/Tilt” **Animate** App.
- Select fixtures 21 through 24 by holding fixture [21] button and tapping fixture [24] button (or tap them individually in the order that you want them to animate).
- Touch **Create** and the Pan/Tilt animation runs.
- Use the controls described above to set the rate, crossfade, direction etcetera.

**Example 2:**

To create a fanned Pan/Tilt animation across fixtures 21 to 24:

- Fade down all output.
- Clear any previous Pan/Tilt animations. From the Apps screen touch Clear, All (or only clear “Position” animations).
- Open the “Pan/Tilt” Position App.
- Fade up fixture 21, 22, 23 and 24.
- Touch Fan then drag to fan the fixture positions.

You have now created the static look of the animation.

- Open the “Pan/Tilt” **Animate** App.
- Select fixtures 21 through 24 by holding fixture [21] button and tapping fixture [24] button.
- Touch **Create** and the Pan/Tilt animation runs.
- Use the controls described above to set the rate, crossfade, direction etcetera.

You can return to the **Position** app if needed and reposition the animation.

**9.5 Multiple Animations**

If you already have an animation(s) running you can still create another one of the same type (Intensity, Colour or Position) by touching **New Animation**. Select the fixtures to be included then touch **Create**. All of the animations of the selected type are listed in the box.

When multiple animations are running you can switch the controls to any of them by touching their name.

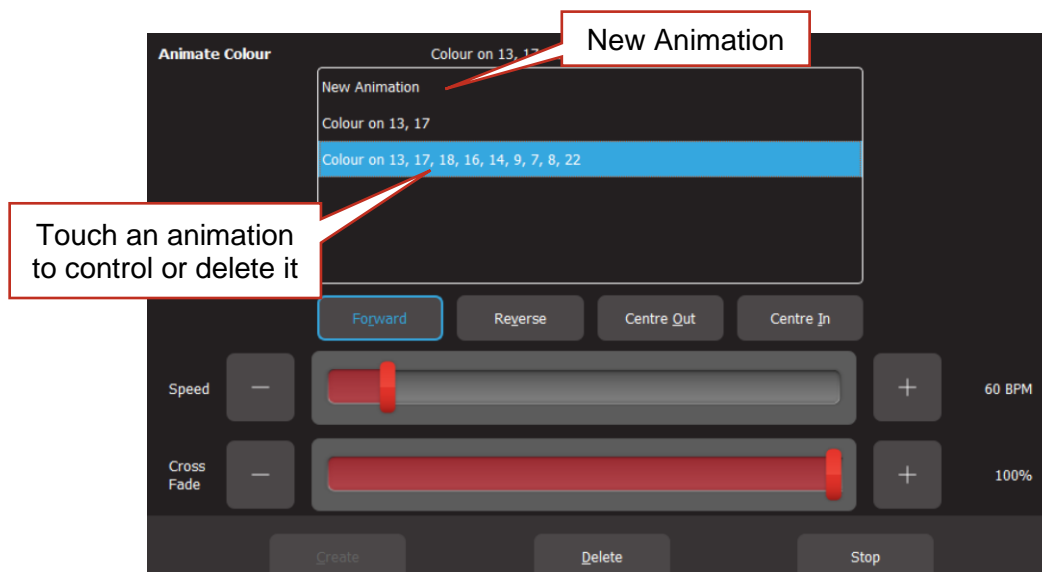
**9.6 Recording Animations**

When you record the output of the Mantra Lite as a cue it includes any animations that are running. Recording an animation will automatically clear that animation from the yellow faders where you created it. If you want to keep the animation running on the output, fade up the red playback fader on which you make the recording and ensure that the Red Master is also up before you record the cue. See section 11 for details on how to record cues.

**9.7 Deleting Animations**

To delete a single animation from the “Live Memory” of the yellow fixture faders, open the Animation app in which it is running (Intensity, Colour or Pan/Tilt), touch the animation number then touch **Delete**

To delete all animations of one type (Intensity, Colour or Pan/Tilt), from the “Apps” screen, touch **Clear** then from the “Animations” pane choose to delete either **Intensity**, **Colour** or **Position** animations.

To delete all animations (and shapes) and restore all fixture(s) to default settings (open, white, centred beam), from the “Apps” screen, touch **Clear** then **All** (trash can icon).

### **9.8 Animations in a Chase**

A chase is cue-list that automatically steps from cue to cue. Any cue in a chase can contain animations so complex effects can be easily created by including animations in a chase.

### **9.9 Animate Speed**

“Live Speed” allows you to override the speed of animations. The changes are only a temporary offset applied to the settings saved in the cue or on the yellow faders. See section 14 for details.

## 10 Shapes App

### 10.1 Overview

The Shapes App provides a quick and simple way of creating continuously moving positions on fixtures that have Pan and Tilt attributes by constantly varying those attributes.

### 10.2 Creating a Shape

*Hint:* You might find it easier to position your fixture(s) before you apply a shape movement to them, however you can still position them after applying the shape.

To create a shape, from the “Home” screen, open the “Apps” page (by touching any fixture icon) then touch the “Position” **Shapes** icon.

Fade up the fixture(s) to which the shape is to be applied. This automatically selects the fixture(s).

You can select the following shapes:

- Ellipse (clockwise or anti-clockwise).
- Rectangle (clockwise or anti-clockwise).
- Triangle (clockwise or anti-clockwise).
- Random.

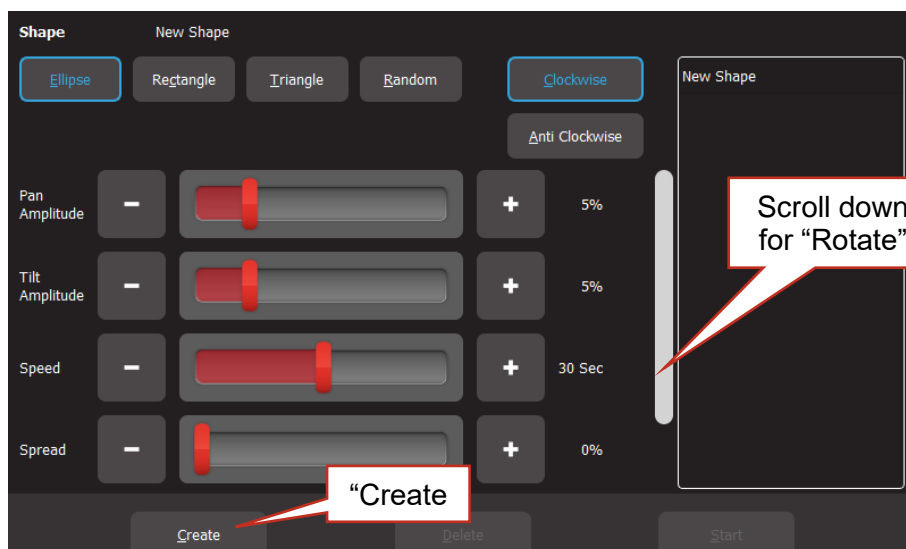

Touch **Create** and the shape runs.

There are controls for:

- Pan Amplitude.
- Tilt Amplitude. (Set pan and tilt to the same amplitude to create a circle when using Ellipse).
- Speed (in seconds).
- Spread (in percentage). Applies when 2 or more fixtures are selected and spreads them around the movement shape. When set to 0%, all fixtures are focused on the same point as they move around the shape. When set to 100% the fixtures are evenly spaced apart as they move around the shape. In between values vary the spread. The “Spread” control does not apply to the “Random” shape.

Scroll down for:

- Rotate (in degrees). Rotates the shape about its axis. Does not apply to the “Random” shape.

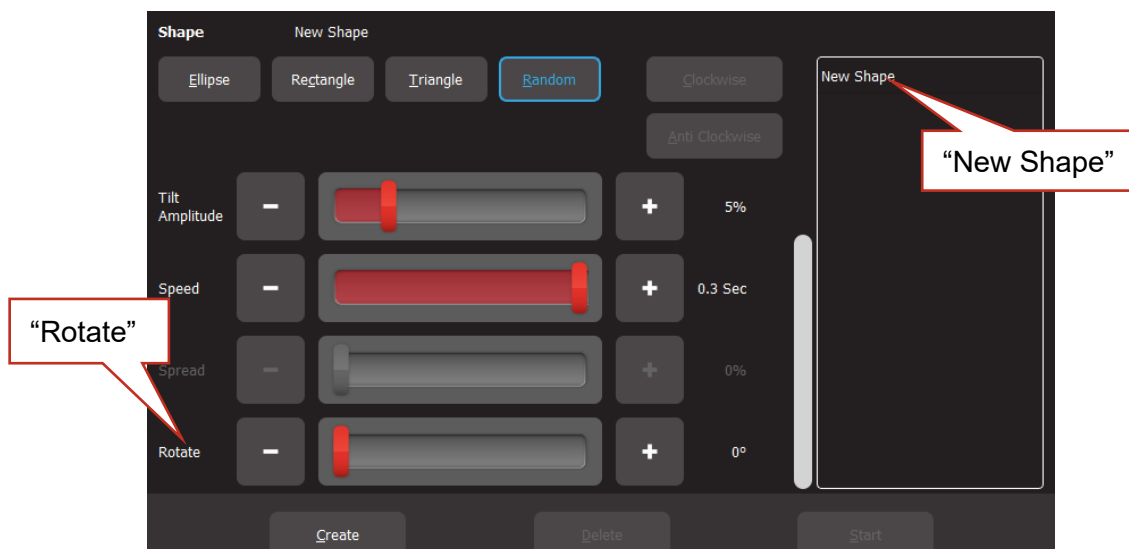

Shapes can be created on other fixtures by selecting **New Shape**, selecting the fixtures and repeating the procedure above.

### 10.3 Recording Shapes

When you record the output of the Mantra as a cue it includes any shapes that are running. Recording a shape will automatically clear that shape from the yellow faders. If the Red fader that you record to is at zero, this will stop the shape on the output. If you want to keep the shape running on the output when you record it, fade up the red playback fader before recording the cue.

See section 11 for details on how to record cues.

### 10.4 Deleting Shapes

To delete a single shape from the “Live Memory” of the yellow fixture faders, open the Shapes app then touch the shape (in the right side pane) then **Delete**.

To delete all shapes (and animations) and restore all fixture(s) to default settings (open, white, centred beam), from the “Apps” screen, touch **Clear** then **All** (trash can icon).

### 10.5 Shapes in a Chase

A chase is cue-list that automatically steps from cue to cue. Any cue in a chase can contain shapes, so complex effects can be easily created by including shapes in a chase.

### 10.6 Shape Speed

“Live Speed” allows you to override the speed of shapes. The changes are only a temporary offset applied to the settings saved in the cue or on the yellow faders. See section 14 for details.

# 11 Recording Cues

## 11.1 Overview

When you have adjusted the intensity and colour of your fixtures and possibly created an animation(s) or shapes, the current output of the Mantra Lite can be recorded into a red fader for later playback. This recording is known as a “Cue” and it contains the intensity and all other attributes such as colour, position etcetera plus any animations that are currently running. It has a “fade in” time and a “fade out” time.

If you record a cue to a Red Playback that already contains a single cue and choose “Add”, then you automatically create a "Cue-list".

## 11.2 Memories / Pages

There are 10 red playback faders and 10 pages of memory giving a total of 100 memories. Each memory can contain a single cue or a “Cue-list” that contains up to 250 cues. A maximum of 1000 cues can be recorded. If a Mantra Wing(s) is connected, cues and cue-lists can be recorded in additional locations. See section 24 for the actual capacity of your configuration.

- Repeated taps of the [Page] button will step through the 10 pages of memory.
- To switch directly to a page number; HOLD [Page] and TAP a red fader button [1 to 10].

The current page number is shown in the top left corner of the “Home” screen and the contents of the red playback faders (for the current page) are shown along the bottom of the screen in the 10 “Playback Displayers”. The top part of each playback displayer shows the page/memory number in the form of “P#-M#” (Page number 1-10 - Memory number 1-10).



**“Home” Screen**

## 11.3 Record a Cue

There are two methods available to record the current output onto a Red Playback fader:

1. Tap [Record] then tap the button below the Red Playback fader of your choice [1-10].
2. Tap [Record] then touch the playback displayer of your choice (1-10) on the touch screen.

The recording is made into the current page. You can select a different page (see section 11.2) prior to or after tapping the “Record” button but before selecting the playback number.

The default fade time is applied to both the “Fade In” and “Fade Out” times. To change the default fade time, see section 19.2 To set individual “Fade In” and “Fade Out” times for the cue you have recorded see section 13.

A new cue is automatically given the name “Cue 1”. You can change the name to suit your needs. For example, “Podium” or “Red Wash”. See section 13.5.

All of the attributes of any fixture with an intensity level greater than 0% will be included in the cue. See section 11.5 for details on how to include fixtures with no intensity.

The look on stage can now be played back from the recorded cue. See section 12. This frees up the yellow faders ready for you to create another lighting look and to record it into another cue.

#### 11.4 Record a Cue-list (or Chase)

If you have recorded a cue into a Red Playback fader you can record more cues to it to create a cue-list. A cue-list can be played back by tapping the button below the fader that contains the list. Each time you tap the button, Mantra will perform a crossfade to the next cue in the list. Each cue has its own “fade in” and “fade out” time settings.

To record a cue-list, record the first cue as described in section 11.3. Create the next lighting look on the output of Mantra then record to the same Red Playback number (memory location). When you select that playback number, Mantra asks you to choose either,

- **Overwrite.** This deletes the existing cue and replaces it with your new recording. (A cue-list is not created).
- **Add.** This creates a cue-list and adds the new recording to the list.

Subsequent recordings to this memory location will automatically be added to the cue-list after the current cue without the option to overwrite.

When a cue is recorded to a cue-list it is added after the current cue. The current cue is indicated by a grey bar if the cue is faded down or a red bar if the cue is faded up. To change the current cue, tap the button below its red fader.

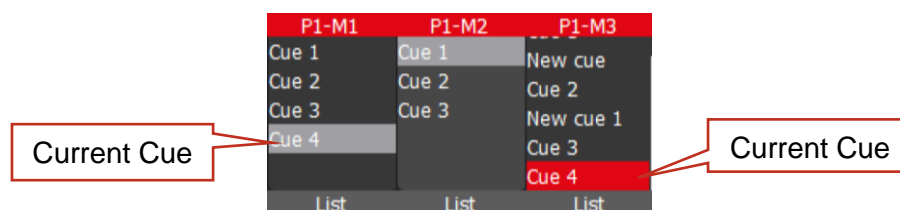

If the current cue is the last cue in the list, then the new cue is given the name “Cue #” where # is the next number.



If the current cue is not the last cue in the list, then the new cue is given the name “New Cue”.

A cue-list is usually manually played back (see the next section), but it can also be run as chase that automatically steps from cue to cue. See section 13.13. Cues can also be given a “Link Time” that will automatically play the next cue in the cue-list. See section 12.4.2

*Hint: It is good practice to regularly save your show.*

## 11.5 Record Fixtures with No Intensity

You can choose to include selected fixtures that have an intensity of 0% when you record a cue. (Normally only fixtures with an intensity level greater than 0% will be recorded in a cue).

To include fixtures with no intensity, tap  [Record], then tap  [Select]. The buttons of all fixtures with intensity greater than 0% are lit. Tap (and light) the buttons of any fixtures with no intensity that you want to include in the cue. Complete the recording in the usual manner by tapping the button below the Red Playback fader of your choice [1-10] or its playback displayer (1-10).

Playing back fixtures that have no intensity can be used for a “Move in Black” or for “Solo Cues” as described below.

### 11.5.1 Move in Black

Playing back a cue that includes fixtures with no intensity is often used with pan and tilt fixtures to position the fixtures without seeing the move on stage. This is commonly called a “move in black”.

A move in black requires two cues:

To program the first cue, fade up the fixtures and position them on stage. Fade them down then record the cue ensuring that you include these fixtures (with no intensity) as described in section 11.5.

To program the second cue that reveals the fixtures in position, fade them up and record the cue to the same cue-list.

When you playback the first cue, the fixtures move into position but are not seen as they have no intensity. When you playback the second cue (which has intensity and the same position) it reveals the fixtures already in position.

### 11.5.2 Solo Cue

When you fade up a normal cue it reveals the fixtures in that cue. If you have output from other fixtures that are not in the cue they will not be affected.

If you want the cue you faded up to be the only output you usually need to fade down all other faders. This can be difficult if you have multiple faders active.

You can simplify this process by recording a “Solo” cue. A Solo cue has the fixture(s) that you want to see but it also includes all of the fixtures you don’t want to see. These fixtures are recorded in the cue with 0% intensity. See section 11.5.

When a solo cue is faded up it will take control of all of the fixtures that are recorded in the cue. Therefore, any fixtures with intensities of zero will fade out.

*Hint: You can create some interesting effects by recording a “solo” cue that has an animation across several fixtures (with intensity) but also includes all other fixtures at zero intensity. Flashing (or fading up) this cue will reveal the animation and black out any other output. Great for highlighting the drummer during a drum solo or other such events.*

## 12 Playback

### 12.1 Overview

Different looks can be recorded on different Red Playback faders so that you can easily change the entire look on stage by using the Red Playback faders. There are 10 red playback faders and 10 pages of memory giving a total of 100 memories. A memory can contain a single cue or a cue-list of up to 250 cues. (A maximum of 1000 cues can be recorded). If a Mantra Wing(s) is connected, cues and cue-lists can also be played back from the wing(s). See section 24 for the actual capacity of your configuration.

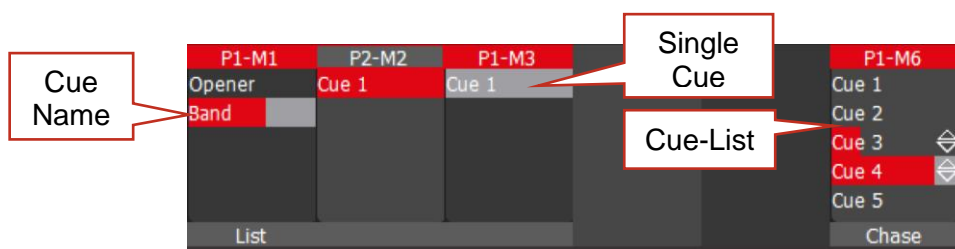

### 12.2 Playback a Cue

To playback a recorded cue, ensure that the Red Playback Master is at full and fade up the Red Playback fader where you recorded the cue (remember to select the correct page). You might want to “clear all” (see section 8.9) or fade down the Yellow master (or all of the yellow fixture faders) before you bring up the Red playback, so that you only see the recorded look on the output.

Unlike the Yellow Fixture faders that only control intensity, the Red Playback faders control all of the attributes of the fixture that have been recorded in the cue. This allows you to smoothly crossfade from one Playback to another with a smooth transition of intensity, colour and position. See Latest Takes Precedence below.

#### 12.2.1 Fade Times

Every cue has a separate “Fade In” time and a “Fade Out” time. When a playback fader is moved, the output level of that master will always progress towards the current physical position of that fader at a rate set by the fade times for that cue.

- On upwards movements of a fader the “Fade In” time is used.
- On downwards movements of a fader the “Fade Out” time is used.

To perform a timed fade quickly move the fader from one end to the other.

For example, if a “Fade In” time of 3 seconds has been set, then to execute the fade in exactly 3 seconds, the fader must be moved from bottom to top in less than 3 seconds. If the fader is quickly faded to the half way position, the fade will take 1.5 seconds to reach this position and then stop. If the fader is then moved to the top of its travel, the fade will take another 1.5 seconds to complete. If you take longer than 3 seconds to move the master then the fade will keep pace with the fader movement.

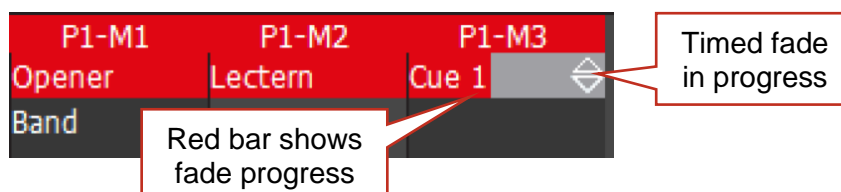

When a cue is recorded it uses the default in and out fade times (2 seconds). If you usually require a different time, you can change the default fade time. See section 19.2.

To change the fade times for a recorded cue, see section 13. The maximum fade time is 30 minutes.

Fade times can also be temporally overridden. See section 14.

## 12.3 Playback a Cue-List

If a Red Playback contains a cue-list you can crossfade to the next cue in the list by tapping its playback button (below its fader). Cue-lists automatically loop back to the beginning after the last cue.

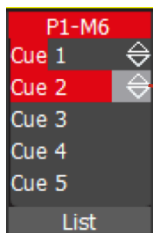

Cross-Fade in progress

To playback the cue-list in the reverse direction HOLD the  [Back] button whilst tapping the playback button.

It is also possible to bypass cues and fade directly to any cue in the list. You can also rearrange the order of the cues and individually name them. See section 13.

## 12.4 Playback a Chase

A cue-list can also be set to automatically run as a chase. See section 13.13

If the chases red fader is at zero, the button below the red fader acts as a chaser flash button. Pressing the button will start the chase from step 1 and keep it running for as long as the button is held down.

### 12.4.1 Fade Times

Every cue in a cue-list has its own “Fade In” time and a “Fade Out” times. When the playback button is pressed, the incoming cue uses its “Fade In” time and the outgoing cue uses its “Fade Out” time. These fade times are also used if the playback fader is moved. Therefore, the playback fader must be at the top position for the entire fade time to be used.

### 12.4.2 Link Times

Every cue in a cue-list can contain a “Link Time” (0.1 seconds to 60 minutes) or “Link Time” can be set to “None”.

- If a cue in a cue-list contains a link time, then when the cue is played, the link time starts counting down. When the time expires the next cue in the cue-list is automatically played.
- If the Link Time is set to “None”, then the button below the red fader must be used to manually play the next cue.

*Hint: If every cue in a cue-list has a “Link Time” value then the cue-list will run continuously in the same manner as a chase but with the difference that in a chase, the time between every step is the same whereas in a cue-list with linked cues, every cue can have a different link time. This allows you to make a chase that changes speed as it runs. See section 13.3 for details on how to set a link time.*

## 12.5 Page Freeze

When you change pages, the Cues in the selected page are copied, in order, to their respective red playbacks. A “PAGE FREEZE” feature prevents the contents of a “live” red fader from being changed if its level is above 5% when a page is changed. The current contents are held until such time as that fader is faded down below 5% when it will be automatically updated with its pending assignment for the new page. This prevents Cues, “crashing in” on stage if their fader is contributing to the output when a different page is selected.

The playback displays at the bottom section of the “Home” screen shows the contents of the 10 Red Playbacks. A “live” playback containing a cue from another page is indicated by a black background.

Black background indicates a "Page Freeze"	P1-M6	P10-M7	P10-M8	Red background indicates the current page
	Cue 1	Cue 1	Cue 1	
	Cue 2			
	Cue 3			

## 12.6 Latest Takes Precedence

The value for each attribute of a fixture (intensity, colour, position, etcetera) could come from multiple places within the console. It might be from a yellow fixture control or it might be from any faded up red playback containing a cue that includes that fixture. The value for each attribute that appears on the output is determined by a method known as LTP (Latest Takes Precedence) and by fader position.

An LTP action occurs when a red fader is raised above zero. When this occurs, the fader will take control of its attributes and they will fade to their levels in that fader following the fader movement. When that fader reaches 100%, it fully overrides all other active faders containing attribute values for the same fixtures. Whilst this fader remains at full no previously active faders have any influence over its fixture attributes.

If another red fader is raised above zero it becomes the latest action and it will take control of the attributes. As this fader is moved, the existing attributes will fade to the new values provided by the incoming cue. When the fader reaches full it fully overrides previously active faders.

Mantra Lite keeps a LTP list and remembers the order in which faders have been raised above zero. The latest fader (at the top of the list) will have total control whilst it is at full level. When a fader is faded down to zero it drops off the LTP list and has no influence on the output. If several faders are in the LTP list (faded up from zero but not yet faded down to zero) and the top of the list fader is faded back down to zero, the next LTP fader in the list will take back control.

The LTP rules apply to all attributes of a fixture: intensity, colour, position, etcetera.

For example:

We have 3 cues recorded on the red playback faders 1 to 3 with the same single LED fixture in each cue. In the first fader the fixture is red, in the second it is blue and in the third it is yellow.

- Fade up fader 1 to full and the fixture fades to red.
- Fade up fader 2 to full and the fixture fades to blue.
- Fade down fader 1 and nothing happens because fader 2 is the latest (LTP) and it is at full.
- Fade up fader 3 and the fixture fades to yellow because fader 3 is the latest.
- Fade down fader 3 and the fixture fades back to blue (the previous latest).

Remember that when the latest red fader to be raised from zero is at full, other faders controlling the same fixtures can be faded down without having an effect.

Yellow fixture faders operate slightly differently to red playback faders. Firstly, they only control the intensity of the fixture. Secondly, if the fixture that the yellow fader controls already has intensity on the output from a cue on a red playback, then when its yellow fixture fader is raised above zero it has no effect on the intensity of its fixture until its yellow level matches the current level of that fixture. It then takes total (LTP) control of the fixture's intensity. See section 13.14 "Edit a Cue".

## 12.7 ICPB Attributes (Filters)

When a cue is recorded it includes all of the **I**ntensity, **C**olour, **P**osition and **B**eam (I C P B) attribute groups. You can choose to exclude (filter) attribute groups when a cue is played back. This is a powerful feature. See section 13.8 for more details.

## 13 Edit Memory

### 13.1 Overview

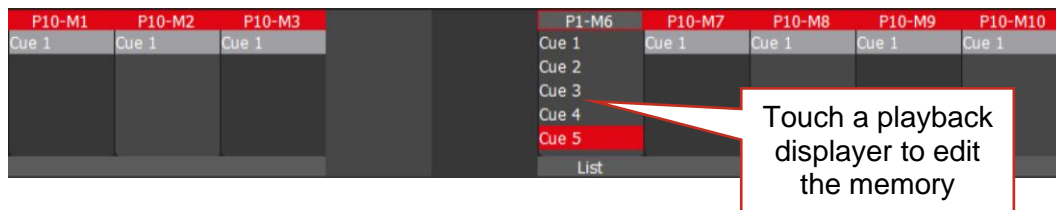

Touching any playback displayer opens the “Edit Memory” screen.

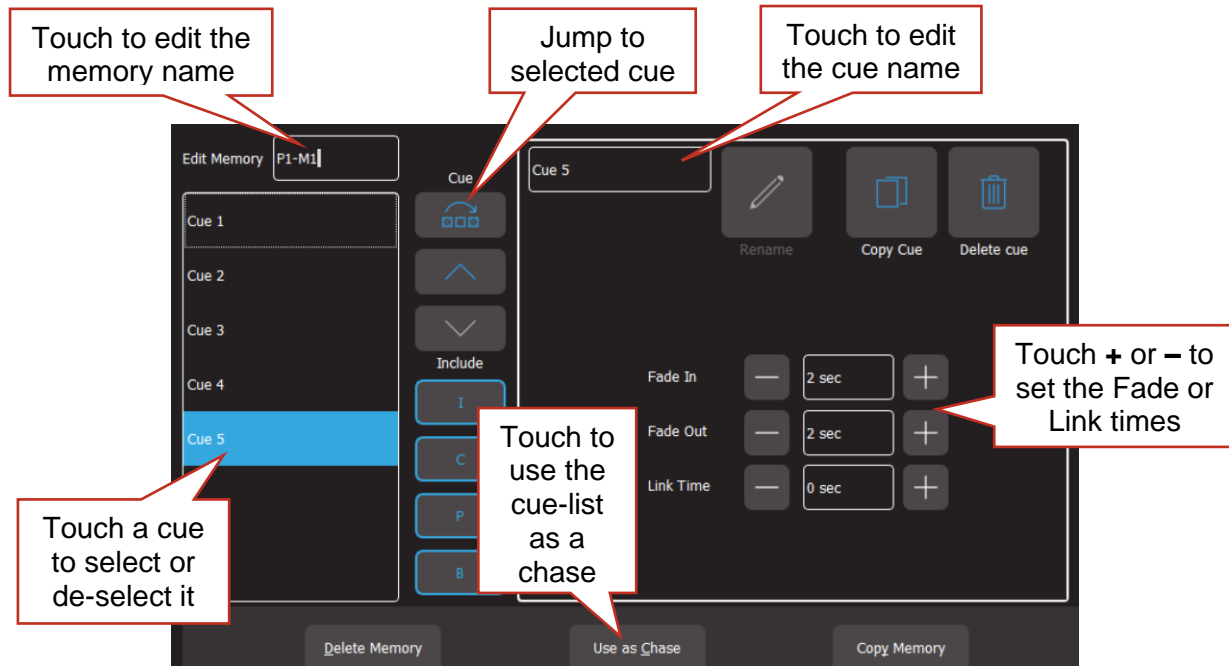

**Edit Memory Screen**

The pane on the left shows the contents of the selected memory. This might be a single cue or a cue-list, depending upon what you have recorded in that memory.

If the memory contains a cue-list you can touch a cue to select/de-select it. Multiple cues can be selected allowing rapid changing of time settings as described below. If multiple cues are selected the screen shows the time settings for the last selected cue.

Tapping the play button of the playback will advance to the next cue in the list and automatically select the currently active cue.

To edit the intensity levels or other fixture attributes in a cue see section 13.14

When a cue(s) has been selected you can perform the following functions:

### 13.2 Fade Times

Every cue has a separate “Fade In” time and a “Fade Out” time (0.1 seconds to 30 minutes). When a playback fader is moved, the output level of that master will always progress towards the current physical position of that fader at a rate set by the fade times for that cue. When the playback button of a cue-list is pressed, the incoming cue’s “Fade In” time is used and the outgoing cue’s “Fade Out” time is used.

To change a Fade time, in the “Edit Memory” screen (see above), touch the **+** or **–** buttons to set the “Fade In” and “Fade Out” times. If you hold a button, it will auto-repeat. See section 12.2 for more details on fade times.

### 13.3 Link Time

Each cue can contain a “Link Time” (0.1 seconds to 60 minutes). If a cue contains a “Link Time”, when the cue is played the “Link Time” starts counting down. When the time expires the next cue in the cue-list is automatically played.

To change a Link time, in the “Edit Memory” screen (see above), touch the **+** or **–** buttons to set the “Link Time”. If you hold a button, it will auto-repeat.

See section 12.2 for more details on link times.

### 13.4 Memory Name

Memory names are by default the page number and the memory number. For example, P1-M1 (Page 1, Memory 1). You can change the default name to something more descriptive. To change the name of a memory, in the “Edit Memory” screen (see above), touch in the **memory name** box, delete the default name then type the new the name of the memory.

To restore the default name, click in the **memory name** box and delete the name then click  **Back/Home**.

*Note.* OSC Remote Triggers always need to be entered in the form P#-M# even if the default memory name or cue name is changed.

### 13.5 Cue Name

To change the name of a cue, in the “Edit Memory” screen (see above), select that cue then in the “Cue Edit” pane touch the cue name. A pop-up keyboard appears allowing you to change the name of the cue. Touch **Rename** (or **[Enter]** on the pop-up keyboard) to finish.



### 13.6 Jump to Cue

When you tap a playback’s button you fade to the next cue in the cue-list. If you want to bypass cues and fade directly to any cue in the list, in the “Edit Memory” screen (see above), select the cue you want to fade to and touch



*Hint:* This function is useful if you have a long cue-list and you want to quickly playback a cue without stepping through all of the intermediate cues.

### 13.7 Change Cue Order

To change the order of the cues in a cue-list, in the “Edit Memory” screen (see above), select the cue(s) to be moved then move the selected cue(s) by touching the  (move up) or  (move down) buttons.

### 13.8 Include ICPB Attributes (Filters)

When a memory is recorded it includes all of the **I**ntensity, **C**olour, **P**osition and **B**eam (I C P B) attribute groups. You can choose to exclude attribute groups when a memory is played back. In the “Edit Memory” screen (see above), touching an attribute group (**I C P B**) excludes that group from the playback. A blue border around the attribute means that it is included. The selection applies to all cues in the cue-list.

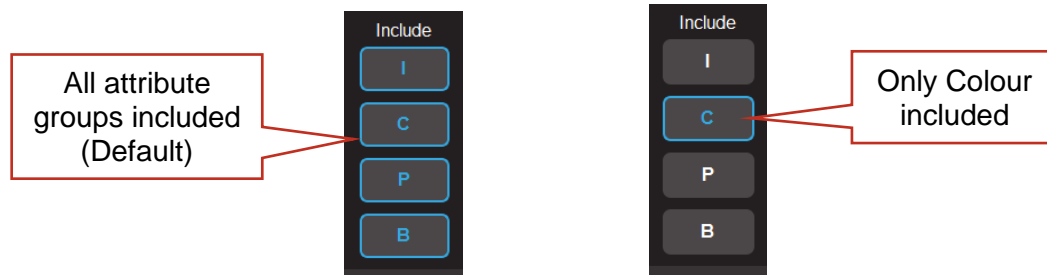

This is a powerful function because it allows you to independently playback groups of attributes of your fixtures.

For example, you have some fixtures that have intensity, colour and position attributes and you want to randomly playback different combinations of colour, position and intensity.

Follow these steps,

1. Record a cue-list that has 5 different cues. Each cue has a different position and a different colour.
2. Use the “Copy Memory” button (see below) to make a copy of the cue-list.
3. Edit the first cue-list and de-select I, P and B leaving only C (colour) included. This is now a colour only cue-list.
4. Edit the copied cue-list and de-select C and B leaving only I and P (intensity and position) included. This is now an intensity and position only cue-list.

Playing the Intensity and Position cue-list steps the fixtures through the 5 positions without affecting the colour. Playing the Colour cue-list steps the fixtures through the 5 colours without affecting the position or intensity.

This gives you 25 possible combinations of colour and position from only 5 cues.

Another possibility is to record individual cues filtered only for colour (or any attribute group) and record them on separate red playbacks. You can now use the flash buttons (below the red faders) to busk change colours without affecting any other attributes of the fixtures.

### 13.9 Copy Cue

To copy a cue in a cue-list select the cue in the “Edit Memory” screen (see above) then touch **Copy**. A copy of the selected cue is added to the end of the cue-list.

### 13.10 Copy Memory

A memory is the contents of a playback. It might be a single cue or a cue-list. To copy a memory, in the “Edit Memory” screen (see above), touch **Copy Memory**. The home screen opens and all playback displays flash red. Touch a flashing red playback to make a copy. You can select a different **Page** if required, prior to touching a playback.

*Hint: See section 13.8 for details on making copies with different filters.*

### 13.11 Delete Cue

To delete a cue(s) in a cue-list select the cue(s) in the “Edit Memory” screen (see above) then touch **Delete Cue**.

### 13.12 Delete Memory

To delete a memory, in the “Edit Memory” screen (see above) touch **Delete Memory**. If the memory contains a single cue or a cue-list the entire memory will be deleted.

### 13.13 Chase

If a memory contains a cue-list you can choose to use it as either a “List” where you manually playback the cues or use it as a “Chase” where it automatically steps through the list at a rate that you set.

To change a cue-list into an automatically stepping “Chase”, in the “Edit Memory” screen (see above) touch **Use as Chase**. The list will automatically increment through the steps using the speed and crossfade settings that you set.

Select the tabs to set the speed, crossfade and direction of the chase.

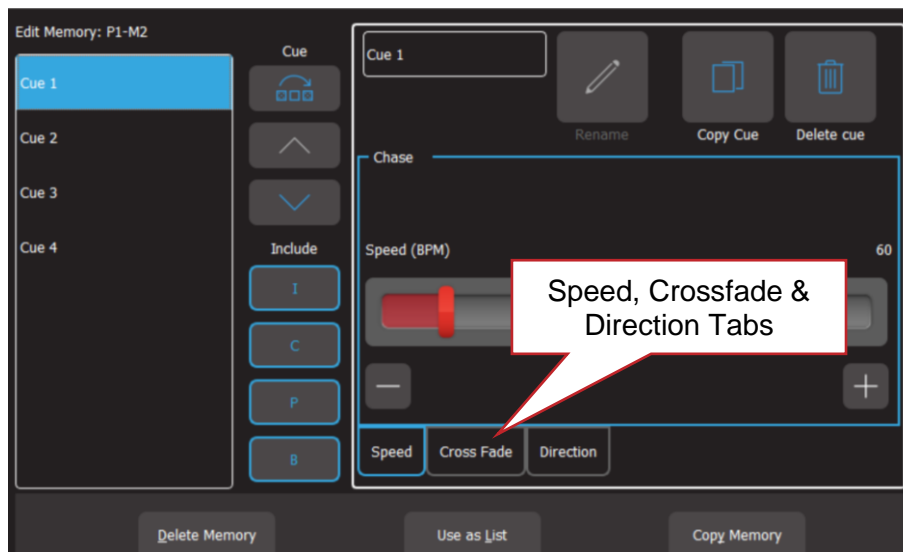

#### Speed Tab:

Use the slider or the + and – buttons to adjust the speed in BPM (Beats Per Minute).

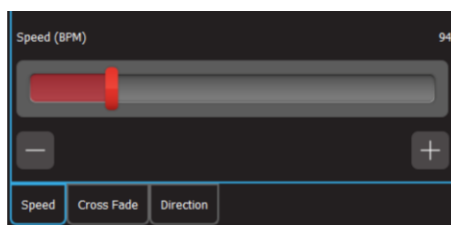

#### Crossfade Tab:

Traditionally chases will snap (instantly switch) from step to step but you may also set a “Cross Fade” value so that it will fade from step to step. Use the slider or the + and – buttons to adjust the % (percentage) of the step time that is used for the crossfade.

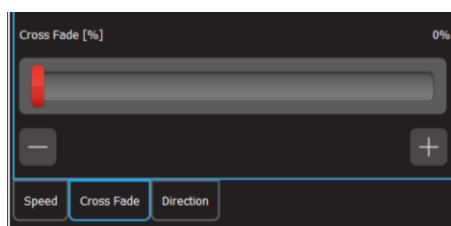

For example, if the chase speed is set at 60 BPM (which is one step per second), then with crossfade set at 0% (that is, no fade), the chase will wait for one second, then snap to the next step. None (0%) of the available speed time will be used for crossfading.

If the crossfade is set to 50%, then the chase will perform a 0.5 second crossfade to the next step, wait for 0.5 seconds and then perform the next crossfade. That is, 50% of the time is used to perform a crossfade and 50% of the time is spent waiting before starting the next crossfade.

If the crossfade is set to 100%, then the Chase will use all of the time performing a crossfade to the next step. When the crossfade is complete, the next crossfade will commence immediately.

**Direction Tab:**



The choices are, **Forward**, **Random** or **Backwards**.

You can manually step a chase by tapping its playback button (below its red fader).

*Hint: Set a low speed if you want to manually step the chase.*

To manually step in the reverse direction, HOLD the  [Back] button whilst tapping the playback button.

Chases automatically stop when their red fader is at zero.

To change a chase back to a cue-list touch **Use as List**.

### 13.13.1 Flash a Chase

If the chases red fader is at zero, the button below the red fader acts as a chaser flash button. Pressing the button will start the chase from step 1 and keep it running for as long as the button is held down.

### 13.14 Edit a Cue

To edit the intensity or attributes of a fixture in a cue, first bring down all yellow and red faders, then push up the red playback fader that contains the cue/cue-list and play the cue that you wish to edit. Fade up the Yellow master.

- To edit the intensity of a fixture, fade the fixtures yellow fader up from zero. When the fader matches the current level in the cue, the yellow fader will take control of the intensity. Set the intensity to the required level.
- To edit the other attributes of a fixture, select the appropriate App (Colour, Position, Beam / Other). Select the fixture(s) to be edited then use the App to make the change.

To update the cue press  [Record] then press and HOLD (for 1 second) the button below the Red Playback fader which contains the cue. The cue will be overwritten with the edited values.

### 13.15 Edit Animations and Shapes

Recorded animations and shapes cannot currently be edited (future feature).

If you need to change an animation or shape recorded in a cue, create a new animation or shape then overwrite the existing cue by pressing  [Record] then press and HOLD (for 1 second) the button below the Red Playback fader which contains the cue.

## 14 Live Speed

### 14.1 Overview

“Live Speed” allows you to override the fade times and speeds of cues, chases, animations and shapes. The changes are only a temporary offset applied to the settings saved in the cue or on the yellow faders. The settings in recorded cues are not altered. Live Speed overrides are not saved when you save your show.

From the “Home” screen touch **Live Speed**.

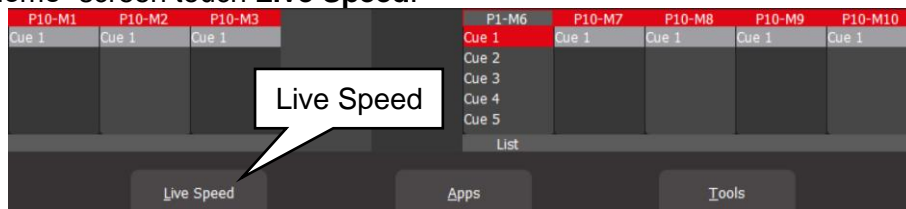

**“Home” Screen**

The “Live Speed” screen opens:

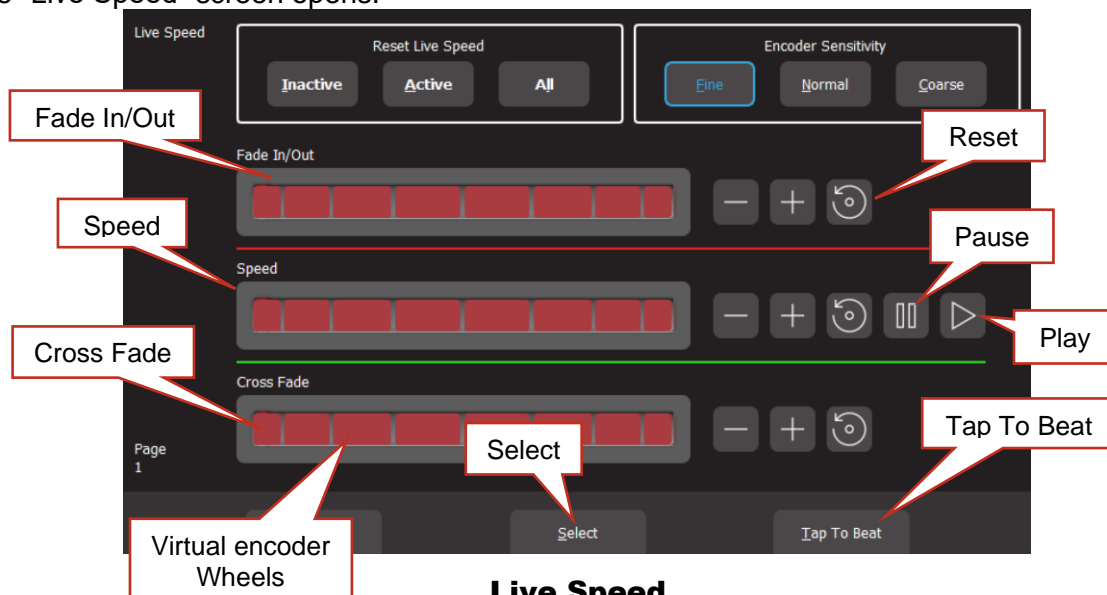

**Live Speed**

The “Live Speed” screen has controls to override the following parameters:

- “Fade In/Out” times of a cue.
- “Speed” “Pause”, ”Play” of a chase, animation or shape.
- “Crossfade” of a chase or animation.
- “Tap To Beat” to set the speed of a chase, animation or shape.

Each set of controls only becomes active when one of the above parameters is either active on the output or “selected” as described below.

For example, if a chase is running on the output, then only the “Speed”, “Crossfade” and “Tap To Beat” controls are active.

You can use either the virtual encoder wheels or the + or – buttons to override fade, speed or crossfade. Moving an encoder wheel to the right or touching + increases the value by multiplying the recorded value. Moving it to the left or touching - decreases the value by dividing the recorded value. Therefore, if the recorded value is small, it will take a large variation to see the change. If the recorded value is 0 then it cannot be changed.

The sensitivity of the encoder wheels can be set to either **Fine**, **Normal** or **Course**.

## 14.2 Select

When the Select button is grey, the controls will override all live output.

If you touch **Select** it turns blue and you can now choose which playback to override by tapping the buttons below the playbacks. Multiple playbacks can be selected and or deselected. The LED in the playback button lights to show it is selected. A playback does not have to be active on the output when you use “Select” allowing you to make blind changes.

Touch **Select** again to return to live output control.

## 14.3 Tap to Beat

You can set the speed of a chase, animation or shape and by tapping the beat.

Play the chase, animation or shape on the output then from the “Home” screen press **Live Speed**.

Tap the **Tap to Beat** button at least 4 times at the desired rate. Mantra Lite averages all of your taps to set the speed. If you have tapped a speed and then want to change it, pause for 2 seconds then start tapping again (at least 4 taps).

If you have multiple chases, animations or shapes running, you can use **Select** as described above to choose which ones you will affect when you Tap To Beat. This also allows you to set the rate if the red fader is down (not playing on the output).

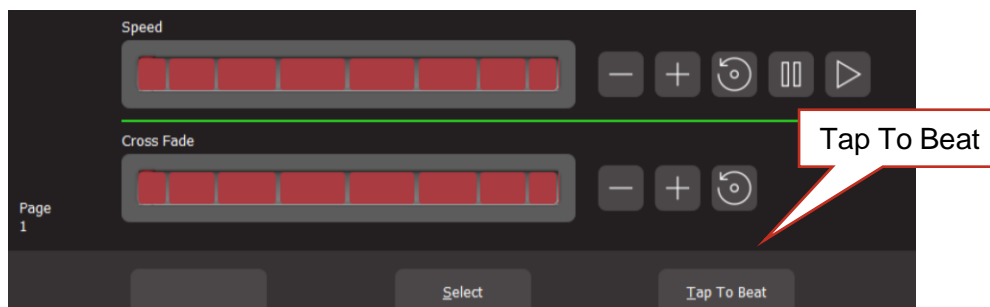

## 14.4 Pause/Play

You can pause or play a chase, animation or shape.

Play the chase, animation or shape on the output then from the “Home” screen press **Live Speed**.

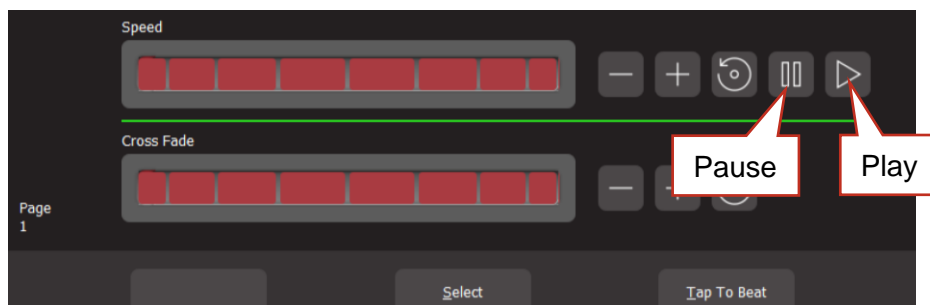

Touch || to pause. Touch ► to play.

If you have multiple chases, animations or shapes running, you can use **Select** as described above to choose which ones you will affect when you pause or play.

### 14.5 Override Indicators

The playback section of the home screen shows the following symbols when a playback has been overridden by the “Live Speed” controls:

- “>” indicates that the fade, speed and or crossfade has been overridden.
- “||” indicates that the chase is paused.

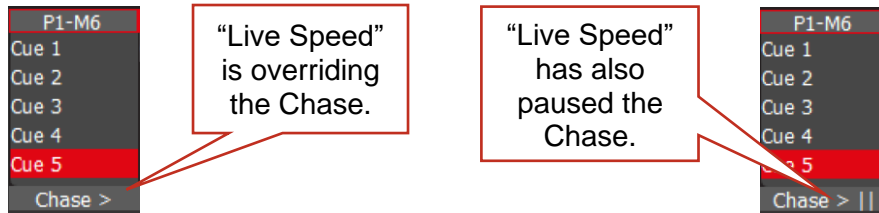

### 14.6 Reset Live Speed

Any changes made by “Live Speed” can be reset to normal.

The “Fade In/Out”, “Speed” and “Crossfade” controls each have individual  [Reset] buttons.

You can also reset “all” (Fade In/Out”, “Speed” and “Crossfade) parameters:

- When the Select button is grey you can choose to reset “Inactive”, “Active” or “All”.

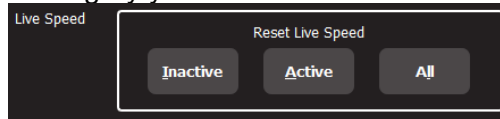

- When the Select button is blue you can choose to reset “Selected” instead of “Active”.

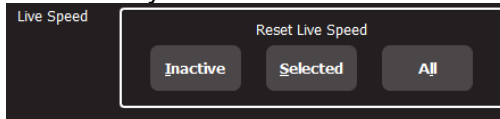

## 15 Flash

You may Flash any fixture or multiple fixtures, any Playbacks (containing a single cue or a chase) or any multiple combination of the above at the one time. The only limit is your ability to hold down multiple buttons. The FLASH function is a momentary action and all actions are instantaneous.

- The buttons below the "Yellow" fixture faders act as intensity [**Flash**] buttons ONLY when the "Home" screen is displayed. At other times they act as fixture select buttons.
- The buttons below the "Red" playback faders act as playback [**Flash**] buttons ONLY when:
  - The red fader contains a cue-list that contains a single cue
  - The red fader contains a cue-list set to "Chase" mode and the fader is at zero. Pressing the button will start the chase (always at step 1) and keep it running for as long as the button is held down

*Note: If a red fader contains a cue-list set to "List" mode, its button acts as a "Go" button to fade to the next cue in the list.*

### 15.1 Flash Level

To set the flash level, from the "Home" screen press **Tools, Setup**. Drag the virtual "Flash Level" slider to set the level.

- For fixtures (yellow) it sets the intensity level of a fixture when it is flashed.
- For Playback (red) it sets the percentage of the intensity levels recorded in the cue. Fixture attributes (colour, position etcetera) are always flashed to their recorded level.

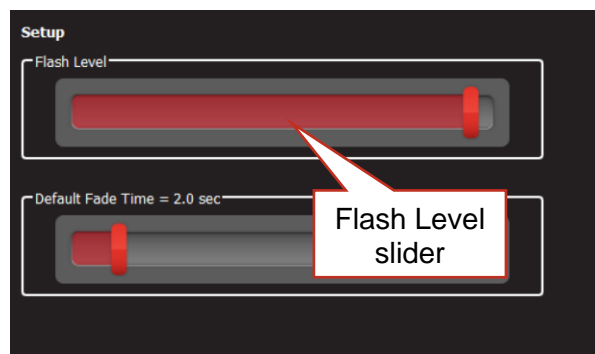

**Setup**

## 16 Remote Triggers

### 16.1 Overview

The Mantra Lite can be controlled by “Remote Trigger Inputs” and it can also send messages to other devices by “Remote Trigger Outputs” via the RJ45 Ethernet network connector.

There are 3 “message types” of remote trigger inputs available,

- OSC (Open Sound Control)
- UDP (User Datagram Protocol)
- TCP (Transmission Control Protocol).

All types of message can be used to perform any of the following “Actions”,

- Play Memory (with the option to turn all “Other Cues Off). Plays the specified memory at the specified level and fade time
- Next Cue. Plays the next cue in the specified memory
- All Cues Off
- Override. Enable or disable the override input. See section 4.12.4

There are 2 types of remote trigger outputs available:

- OSC
- UDP

These can be used to send a “Cue Change” message to another device whenever the level of any recorded cue changes on the output. See section 16.5

### 16.2 Network Connection

Use the “ETHERNET” connector on the rear of the Mantra Lite to connect to the network connection of your computer or network.

When using Microsoft Windows to connect to a Mantra Lite, you must set your computers network profile to “Private”. To change the network profile for a wired network, click **Start, Settings, Network & Internet, Ethernet**, then click your network adapter and choose the “Private” profile.

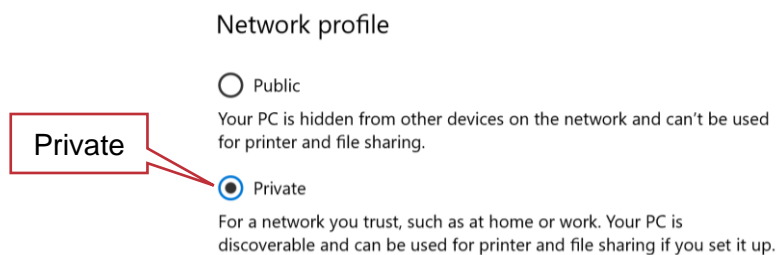

See section 19.7.1 for details on how to set the network address of the Mantra Lite.

### 16.3 Add a Remote Trigger

To open the Remote Triggers screen, touch **Tools, Setup, Remote Triggers**.

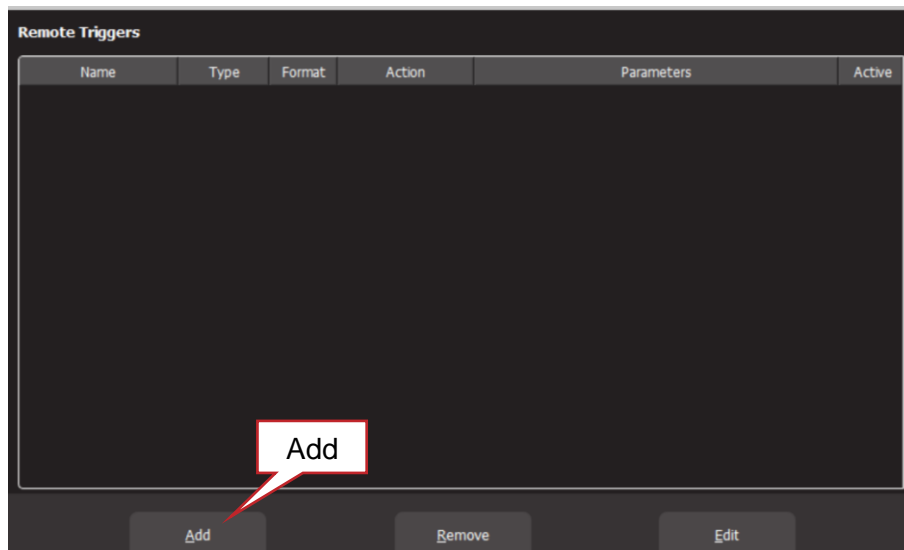

#### Remote Triggers

To create a new remote trigger touch, **Add**.

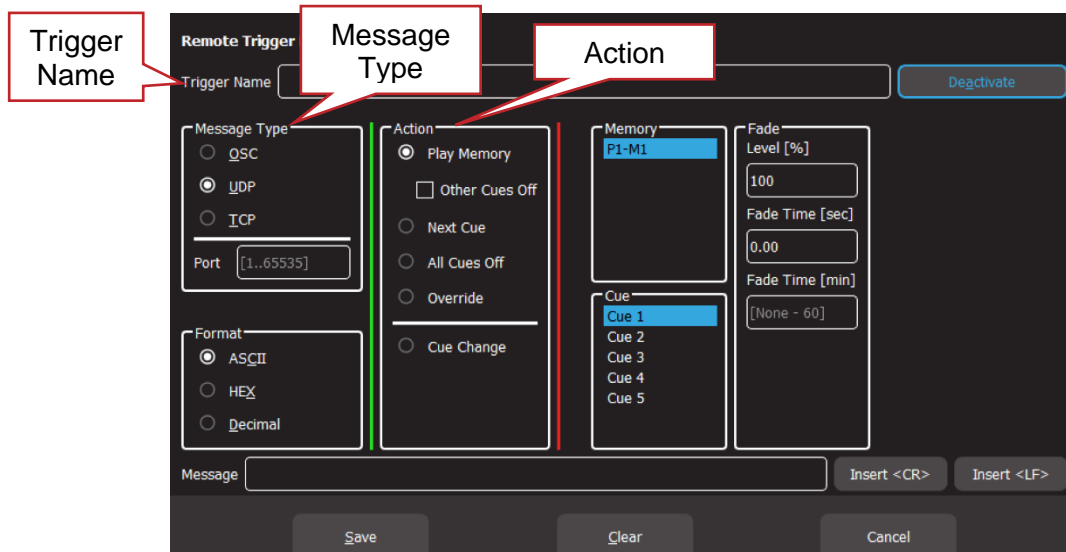

#### Remote Trigger Editor

Enter a descriptive name for the trigger in the “Trigger Name” pane at the top.

Select the “Message Type” of remote trigger:

- OSC (Open Sound Control). See section 16.3.1
- UDP (User Datagram Protocol). See section 16.3.2
- TCP (Transport Control Protocol). See section 16.3.2

Select the “Action” that you want the message to perform:

- Play Memory. See section 16.3.3
- Next Cue. See section 16.3.5
- All Cues Off. See section 16.3.6
- Override (enable/disable). See section 16.4.1

Select or enter all the parameters for the selected “Action” as described below then touch **Save**.

### 16.3.1 OSC Remote Triggers

OSC (Open Sound Control) is a protocol for real time control between computers and multimedia devices. OSC messages sent from an OSC controller can be used to control the Mantra Lite. Mantra Lite can also send OSC messages to acknowledge whenever the level of any recorded cue changes. See section 16.5

In the “Remote Trigger Editor” screen (above), enter a descriptive name for the trigger in the “Trigger Name” pane at the top.

To use OSC, Mantra Lite needs to know the “Port Number” that is used by the the device sending the OSC message. If the sending device uses a specific port number, then enter the same port number in the Mantra Lite. If not, choose a random port number in the range 1 to 65535 and enter the same number in the sending device and the Mantra Lite.

Mantra Lite will respond to an OSC message and follow the instructions contained in the message to either “Play Memory”, advance to “Next Cue”, “All Cues Off” or enable/disable “Override”. These actions are all described below and also in their own sections as referenced at the end of this section.

To assist you in programming the OSC messages into your OSC controller, when you select a type of “action”, the Mantra Lite shows you the message it needs to receive for that action. This allows you to simply copy that message into your OSC controller and edit the message if necessary, as described below.

#### “Play Memory” Action.

When you select a “Play Memory” action, the message pane at the bottom of the screen shows you a template for the OSC message that is required to play a memory with variables that you can replace with actual values.

The template is:

```
/PlayMemory/Page=$p/Memory=$m/Cue=$c/Level=$l/Fade=$t
```

The variables are:

\$p	Page Number (1-10)
\$m	Memory Number (1-10)
\$c	Cue Number (1-...)
\$l	Level (0-100)
\$t	Fade time in milli seconds (0-...)

The fade time is entered in milli-seconds. 1 second = 1000 milli-seconds.

In your OSC controller, enter the message as shown in the template but replace each of the “\$variables” with the actual values that you require for the trigger.

For example, to play Page 1, Memory 2, Cue 3 at a level of 100% with a fade time of 4 seconds, the OSC message becomes:

```
/PlayMemory/Page=1/Memory=2/Cue=3/Level=100/Fade=4000
```

To fade down the cue, send an OSC message with a level of 0%:

```
/PlayMemory/Page=1/Memory=2/Cue=3/Level=0/Fade=4000
```

The “Fade Time” is the time for the Page/Memory to fade up or down to the level set by the “Level” value when triggered by the message. This time should not be confused with the fade times of the cue(s) in the playback. Every cue has its own “Fade In” and “Fade Out” time as set when the cue is recorded or edited. If you want to play a cue using only an OSC fade time, it is advisable to set the cues own “Fade In” and “Fade Out” times to 0 seconds so that the OSC fade

time is the only time that affects the cue. If you want to play a cue using only the cues fade time it is advisable to set the OSC fade time to 0 seconds so that the cue fade times are the only times that affects the cue.

See section 16.4 for more information on playing cues and the interaction between red playback faders and remote triggers.

*Note: Only one OSC “Play Memory” Remote Trigger is allowed to be saved but it can be used to play any memory to any level. When you have saved an OSC “Play Memory” Remote Trigger, Mantra Lite listens for all OSC “Play Memory” messages. Each received message contains the instructions for the memory to play including its level and fade time so only one remote trigger is required.*

*Note: OSC messages always use memory numbers and cue numbers. Mantra Lite allows you to rename memory numbers and cue numbers. If a memory or cue has been renamed, the OSC message must still use the original memory number and cue number.*

*For example;*

*If “Cue 3” was renamed “Blue Wash”, the OSC message must still use the name “Cue 3”.*

*If “P1-M1” was renamed “Act1”, the OSC message must still use the name “P1-M1”.*

See section 16.3.3 for more information on “Play Memory”.

#### “Next Cue”, “All Cues Off” and “Override” Actions

When you select a “Next Cue” or “All Cues Off” action, then select a Memory or when you select the “Override” action and either “Enable” or “Disable”, the message pane at the bottom of the screen shows you the actual OSC message that is required to trigger the action. Copy the exact message into your OSC controller.

- See section 16.3.5 for more information on Next Cue
- See section 4.12.4 for more information on Override
- See section 16.5 for more information on Cue Change

### **16.3.2 UDP and TCP Remote Triggers**

UDP (User Datagram Protocol) and TCP (Transport Control Protocol) are Internet protocols and can be used to send messages to control the Mantra Lite. Many third-party control systems can send UDP or TCP messages and hence be used to control the Mantra Lite.

Mantra Lite can also send UDP or TCP messages to other devices to acknowledge whenever the level of any recorded cue has changed and hence that the received message has been executed. See 16.5

In the “Remote Trigger Editor” screen (see above), enter a descriptive name for the trigger in the “Trigger Name” pane at the top.

Mantra Lite needs to know the “Port Number” used by the the device sending the message. If the sending device uses a specific port number, then enter the same port number in the Mantra Lite. If not, choose a random port number in the range 1 to 65535 and enter it in the sending device and the Mantra Lite.

UDP and TCP messages can be sent in different formats. Select the “Format” that is used by the sending device.

- **ASCII** (American Standard Code for Information Interchange)
- **Hex** (Hexadecimal)
- **Decimal**

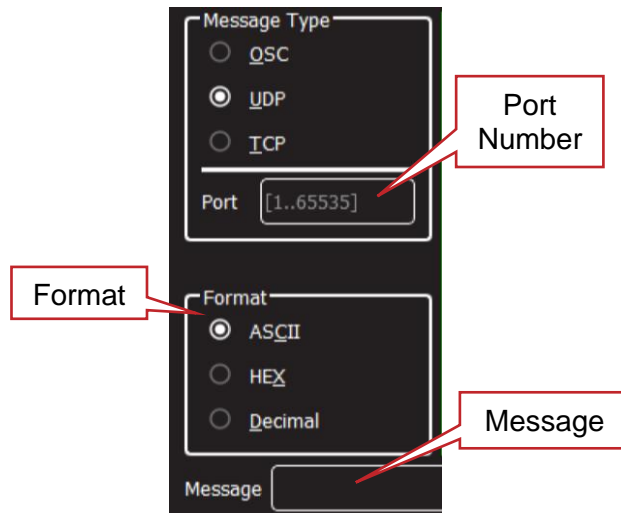

The TCP or UDP message that is sent from the controlling device can be any combination of text or numbers. This can be any descriptive text that you like. The message does not define any parameters of the action such as Memory Number, Cue Number, Level or Fade time.

In the “Message” pane, enter the exact message that will be sent by the controlling device. When the received message exactly matches the message in the message pane, the action and parameters as set in the “remote trigger editor” screen will be triggered.

The actions that can be triggered are either “Play Memory”, advance to “Next Cue” or enable/disable “Override”. These actions are all described in their own sections.

- See section 16.3.3 for more information on Play memory
- See section 16.3.5 for more information on Next Cue
- See section 4.12.4 for more information on Override

For example, the message might be “House Lights On” and when received, it will trigger an action to “Play Memory, P1-M12, Cue 1 at 100% Level with a Fade Time of 10000. Some sending devices will automatically include a <CR> (Carriage Return) or <LF> (Line Feed) at the end of each message. If the sending device ends the message with a CR or LF, you must also include these in the message pane because the message that you enter must exactly match the message that is sent by the transmitting device.

A <CR> or <LF> cannot be typed directly into the message pane. To insert a Carriage Return or Line Feed into the message pane, touch either **Insert <CR>** or **Insert <LF>**.



A CR or LF are also used to separate consecutive messages. This allows the Mantra Lite to recognise each separate message and it can then use them in separate triggers.

*Hint: Adding a <CR> or <LF> to end of each message is not mandatory but it is good practise. They allow the Mantra Lite to always knows that the message has ended.*

**16.3.3 Play Memory.**

“Play Memory” is an “Action” that can be triggered by any of the 4 “Message Types” (Contact, OSC, UDP, TCP). The 4 message types are described above. When the “Play Memory” action is triggered it will play the selected cue.

- OSC messages will play a memory/cue using the parameters in the OSC message. See section 16.3.1
- Contact, UDP and TCP messages will play the selected memory/cue using the parameters in the remote trigger screen. See section 16.3.2

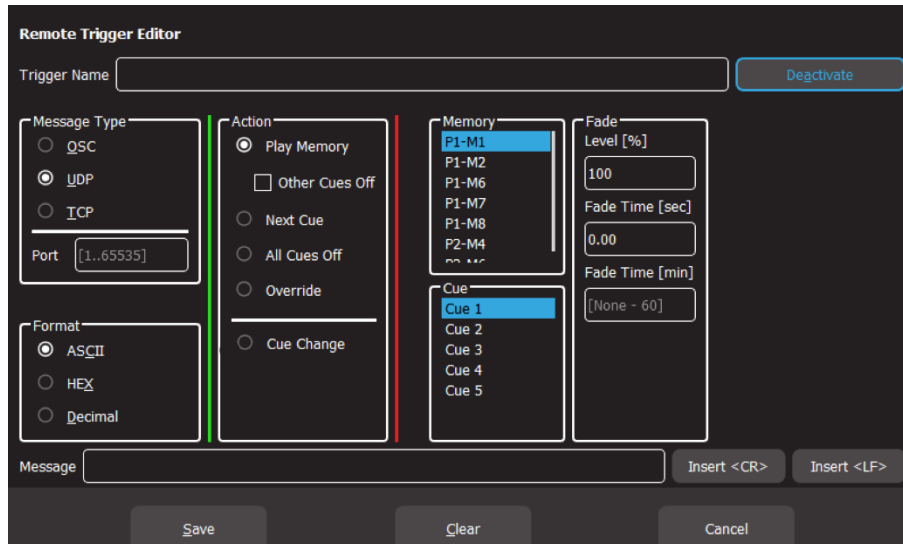

- To fully fade up a memory use a trigger with the Fade Level set to 100%
- To fade down a memory use another trigger with the Fade Level set to 0%

The “Fade Level” in the Play Memory trigger is the level for that playback (page/memory).

The “Fade Time” in the Play Memory trigger is the time for the playback (page/memory) to fade up or down when triggered by the message. This time should not be confused with the fade times of the cue(s) in the playback. Every cue has its own “Fade In” and “Fade Out” time as set when the cue is recorded or edited.

- If you want to play a memory using a Remote Trigger fade time, it is advisable to set the cues own “Fade In” and “Fade Out” times to 0 seconds so that the Remote Trigger fade time is the only time that affects the cue.
- If you want to play a memory using the cues fade time it is advisable to set the Remote Trigger fade time to 0 seconds so that the cue fade times are the only times that affects the cue.

See section 16.4 for more information on playing cues and the interaction between red playback faders and remote triggers.

*Hint: Remote triggers can be used to play a single cue at different levels and with different fade times. For example, a memory might contain the cue for “House Lights”. One trigger might fade up the cue to 100% level over 5 seconds. Another trigger might fade the same cue to 50% level over 20 seconds.*

*Hint: If a memory/cue-list is set to play as a chase, using a Remote Trigger fade time will fade up or down the running chase.*

### 16.3.4 Other Cues Off

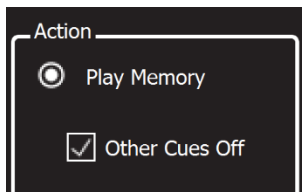

“Other Cues Off” is a tick box option that is available when a “Play Memory” action is selected. If “Other Cues Off” is ticked, playing the selected memory will also fade out all other active cues.

### 16.3.5 Next Cue

“Next Cue” is an “Action” that can be triggered by any of the 4 “Message Types” (Contact, OSC, UDP, TCP). The 4 message types are described above.

“Next Cue” plays the next cue in the selected memory.

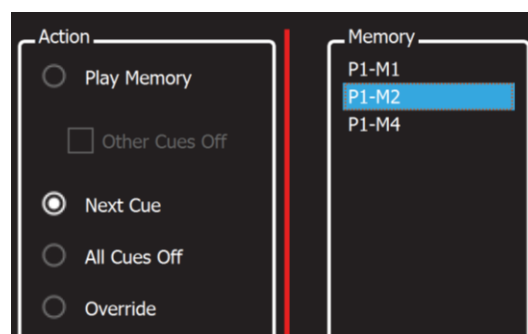

For example, memory P1-M2 (Page 1- Memory 2) contains a cue-list of 5 cues. Cue 2 is currently active. A “Next Cue” action on P1-2 will advance the cue-list to cue 3.

- If the memory is not currently faded up, “Next Cue” advance to the next cue and will fade it up to 100% level.
- If the memory is faded up, “Next Cue” will advance to the next cue and maintain the current fade level.

### 16.3.6 All Cues Off

“All Cues Off” is an “Action” that can be triggered by any of the 3 “Message Types” (OSC, UDP, TCP). The 3 message types are described above. When the “All Cues Off” action is triggered, it will fade out all active cues.

## 16.4 Remote Triggers and Red Playback Faders

Cues can be played back by fading up their red playback faders or by “Remote Triggers”. If you send a remote trigger, it sets the playback level as if you had moved the red fader (this includes the [AllCuesOff] message). Therefore, it is possible that the physical position of a red fader does not match the actual playback level of its cue on the output.

Red playback faders and Remote Triggers operate on a LTP (Latest Take Precedence) basis. If a remote trigger has been used to playback a cue, moving the red fader for that cue through its range causes the fader to take back control of the cue and set its level to the fader position.

A remote trigger can playback a memory from any page, therefore you can have up to 100 active cues (10 memories times 10 pages) and even more with wings connected if the cues have been played by remote triggers. Therefore, to get back to normal (with the red fader positions showing the actual levels) you need to step through all 10 pages and look for any active cues and then move their respective red faders through their range then set them to their required level.

### 16.4.1 Override Disable

“Override” is a function where an Art-Net or sACN input signal from another lighting console “overrides” the Mantra Lites own output. Override is configured in the “Universes” screen. See section 4.12.4. Override can be prevented from occurring by a Remote Trigger “Action” that can be triggered by either OSC, UDP or TCP. It can be set to either “Enable” or “Disable”.

- When “Override” is disabled, it will prevent override from occurring, even if it has been activated in the “Universes” screen
- When “Override” is enabled, it will allow override if it has been activated in the “Universes” screen

### 16.5 Cue Change

“Cue Change” is a Remote Trigger Output.

Whenever the level of any recorded cue changes on the output, a message can be sent via OSC or UDP. This can be used to send a message back to a controlling device, confirming that the Mantra Lite has responded to a remote trigger input.

Mantra Lite needs to know the “Port Number” used by the the device receiving the message. If the receiving device uses a specific port number, then enter the same port number in the Mantra Lite. If not, choose a random port number in the range 1 to 65535 and enter it in the receiving device and the Mantra Lite.

In the “Destination Address” pane, enter the IP address to which the message is to be sent.

“UDP” Cue Change Messages have a flexible format and “OCP” Cue Change Messages have a fixed format. The different formats are described below.

#### “UDP” Cue Change Messages.

In the “Message” pane, type in the outgoing message. You can enter any message text that you like. The following “variables” can be included in the outgoing message:

\$Variables	Parameter
\$n	network name
\$m	memory number [1...100]
\$c	cue number
\$l	level [%]
\$t	fade time [ms]

When the message is sent, the “\$variables” in the message will be automatically replaced with the actual values from the memory that changed level.

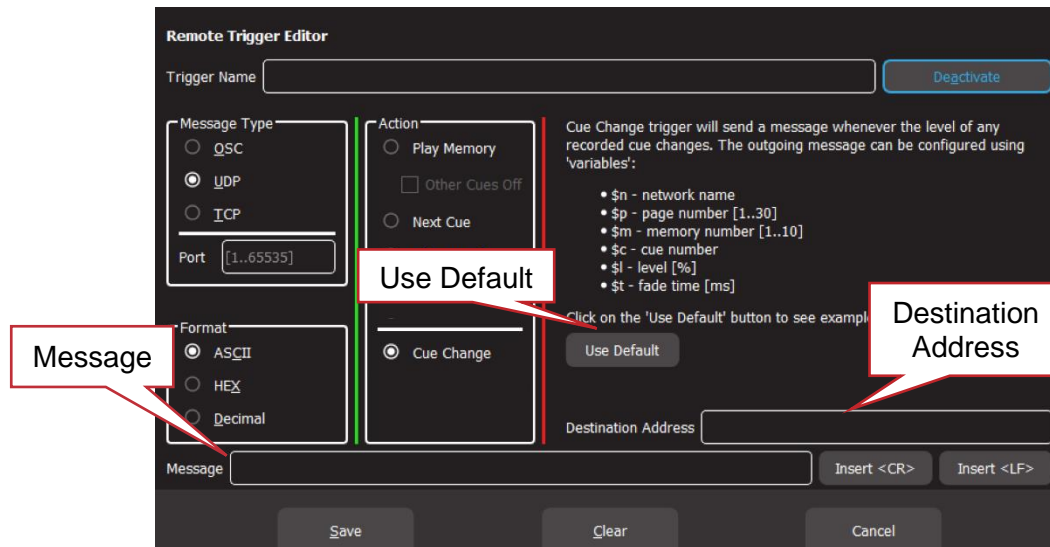

If you touch **Use Default**, the message pane will show a sample message.  
 Mantra:::CueInfo:::\$n:::\$m:\$c:::l=\$l%:::t=\$tms

For example, Memory 1, Cue 1 has the foyer lights at a level of 100%. If you define the “Cue Change” message as:

“Foyer/Memory=\$m/Cue=\$c/Level=\$l”.

When M1-C1 changes level to 100%, Mantra Lite will send the message:

“Foyer/Memory=1/Cue=2/Level=100”

“OSC” Cue Change Message.

The message pane shows the message that will be sent.

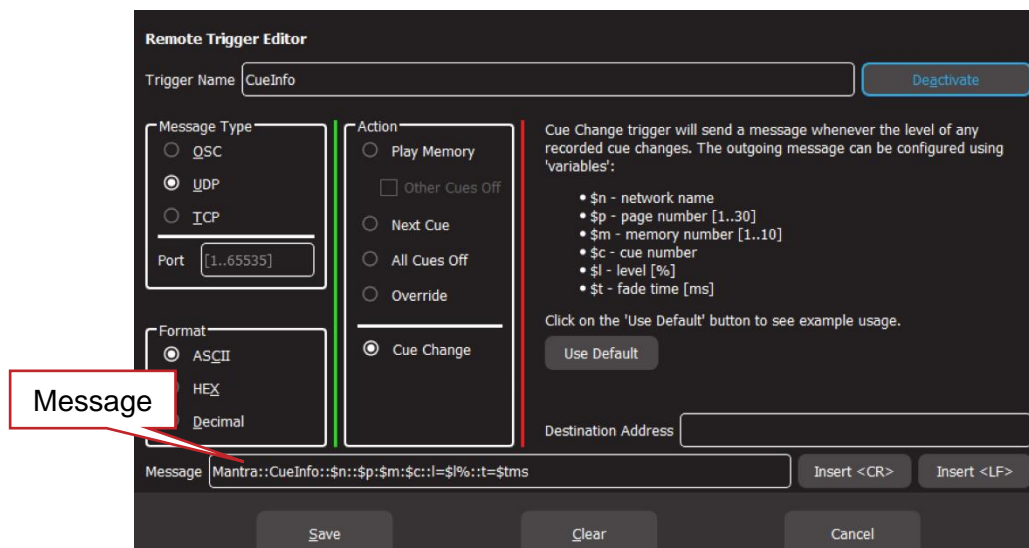

The message format is:

/CueChange/Page=\$p/Memory=\$m/Cue=\$c/Level=\$l/Fade=\$t

When the message is sent, the “\$variables” in the message will be automatically replaced with the actual values from the memory that changed level.

For example, Memory M1-P1, Cue 1 has the foyer lights at a level of 100%. When M1-P1-C1 changes level

to 100%, Mantra Lite will send the message:  
 /CueChange/Page=1//Memory=1/Cue=1/Level=100/Fade=0”

### 16.6 De-activate a Remote Trigger

To de-activate a Remote Trigger, from the home screen touch **Tools, Setup, Remote Triggers**. Touch the remote trigger to select it then touch **Edit**.

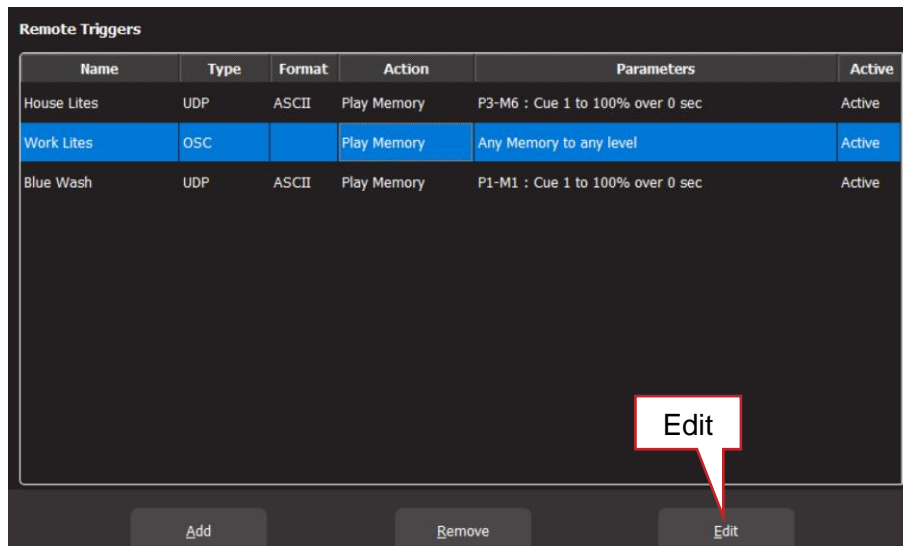

To de-activate the Remote Trigger touch **Deactivate**, then **Save**.



### 16.7 Devices that can send OSC Remote Trigger Messages

Many third-party devices are available that can send OSC messages. Two are examples are,



Elgato StreamDeck ©



TouchOSC App

#### 16.7.1 StreamDeck

Elgato StreamDeck © is an affordable and customizable USB button panel. When the StreamDeck is used with “Bitfocus Companion” software, it enables the StreamDeck to send OSC messages that can be used to control the Mantra Lite via “Remote Triggers”. See section 16.3.1 for more information on OSC remote triggers.

The Companion software is run on a computer that is connected to the same network as the Mantra Lite. The StreamDeck plugs into a USB port of the same computer. The buttons on the StreamDeck are fully programable and each button can be configured to send an OSC message to the Mantra Lite.

The OSC messages can be used to control the Mantra Lite via “Remote Triggers” and can play any cue at any level with any fade time or play the “next cue” in a specified memory (cue-list) or enable/disable “override” mode.

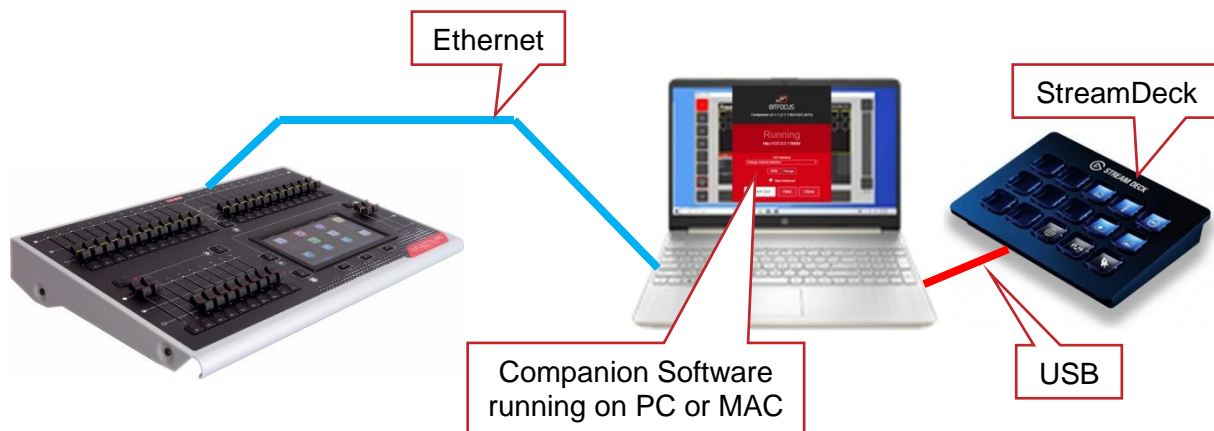

### Typical StreamDeck Setup

This description covers the basics in configuring a StreamDeck button to send an OSC message to the Mantra Lite. You can find information online on how to setup a StreamDeck, how to customise StreamDeck buttons and also about advanced StreamDeck programming.

Companion software can be downloaded from: <https://bitfocus.io/user/downloads>

Run Companion. Check that the “GUI Interface” is set to “localhost / 127.0.0.1”.



Click **Launch GUI**. The GUI opens in your WEB browser.

In the “Instances” tab select **Add by category** then click **Generic, Generic OSC**.

Click the “Config” tab. In the “Target Port” pane, enter a port number”. Choose any random number in the range 1 to 65535. In the “Target IP” pane, enter the IP address of the Mantra Lite to be controlled. The IP address can be found in the Mantra Lites “System Settings”, “Available Networks” screen.

On the Mantra Lite, touch **Tools, Setup, Remote Triggers, Add**. Select **OSC, Play Memory**. Make a note of the message in the message pane so that it can be entered into Companion later on. Enter the same port number that was set in the Companion Config tab. Name the trigger then **Save**.

Back in the Companion GUI, click the “Buttons” tab, click the button that you want to configure. In the “Edit Button” tab on the right, click “Set Button Type” then choose “Regular Button”. In the “Text” pane, type the label for the button. Click “Add key down/on action” then choose “Send message without arguments”.

In the “OSC Path” pane, replace the text with the message previously noted from the Mantra Lite but replace each of the “\$variables” with the actual variables that you require for the OSC message.

For example:

The noted OSC message is:

```
/PlayMemory/Page=$p/Memory=$m/Cue=$c/Level=$l/Fade=$t
```

To play Page 1, Memory 2, Cue 3 at a level of 100% with a fade time of 4 seconds, replace the variables with the required values.....

```
/PlayMemory/Page=1/Memory=2/Cue=3/Level=100/Fade=4000
```

**Note:** The fade time is entered in milliseconds. 1 second = 1000 milliseconds.

To program another StreamDeck button to send a different message, click on the button, set the type, text and enter the same message but replace the variables with different values. For example, to fade down the cue, send an OSC message with a level of 0%.

**Hint:** When programming keys for “Next Cue” or Override, the message generated by the Mantra Lite does not have any variables so simply copy it directly into the Companion “OSC Path” pane without editing it.

**Hint:** It is very easy to make a flash key on the StreamDeck. Program the key down action to play the cue at 100% and the key up action to play the same cue at 0%.

### 16.7.2 Touch OSC

“Touch OSC” is a touch screen app for IOS and Android phones and tablets. It can send OSC messages over Wi-Fi to compatible devices such as the Mantra Lite. The OSC messages can be used to control the Mantra Lite via “Remote Triggers” and can play any cue at any level with any fade time or play the “next cue” in a specified memory (cue-list) or enable/disable “override” mode. See section 16.3.1 for more information on OSC remote triggers.

Touch OSC consists of two parts.

1. The first part is the “Touch OSC Editor”. It is a program on a computer that is used to create the buttons and their commands that can be used in the “Touch OSC App” (see below). The buttons that you create on are fully programable and each button can be configured to send a different OSC message to the Mantra Lite. Touch OSC Editor can be downloaded from [hexler.net/products/TouchOSC](http://hexler.net/products/TouchOSC). Comprehensive help files are available on line for Touch OSC.
2. The second part is the “Touch OSC App”. When the buttons, their OSC commands and their labels have been created in “Touch OSC Editor”, the “current layout” is “Synced” via Wi-Fi to the “Touch OSC App” on the phone or tablet. The computer running the “Touch OSC Editor” and the phone or tablet running the “Touch OSC App” must be connected to the same Wi-Fi network for the “Sync” to occur. The computer running “Touch OSC Editor” is no longer required after syncing unless different buttons need to be programmed. The Touch OSC App is available for free download from your App store.



The phone or tablet running the “Touch OSC App” and the Mantra Lite must be connected to the same Wi-Fi network so that the “Touch OSC App” can send the OSC commands over Wi-Fi to the Mantra Lite. Mantra Lite does not have in-built Wi-Fi so it must be connected via the ethernet connector to an either an existing network that is connected to Wi-Fi or to a Wireless Access Point.

The following is a brief description of how to program one button to play a cue on the Mantra Lite. Multiple buttons can be created and each can perform a different function.

Open the “Touch OSC app” on the phone or tablet. Select “Connections”, “OSC” then enter the IP address of the Wi-Fi that is connected to the same network as the Mantra Lite.

Take note of the “Port (outgoing) number in Touch OSC. This is usually 8000 but you can use any number as long as the same port number is entered in the Mantra Lite remote trigger.

On the Mantra Lite, from the home screen touch **Tools, Setup, Remote Triggers, Add**. Select **OSC, Play Memory**. Write down the message that appears in the message pane. This message will be entered into the Touch OSC Editor later on. Enter the same port number that was set in the Touch OSC App. Name the trigger, then touch **Save**.

Open the “Touch OSC Editor” program. Right click on the virtual device screen and select “Push Button”. The button appears and can be resized, positioned and coloured.

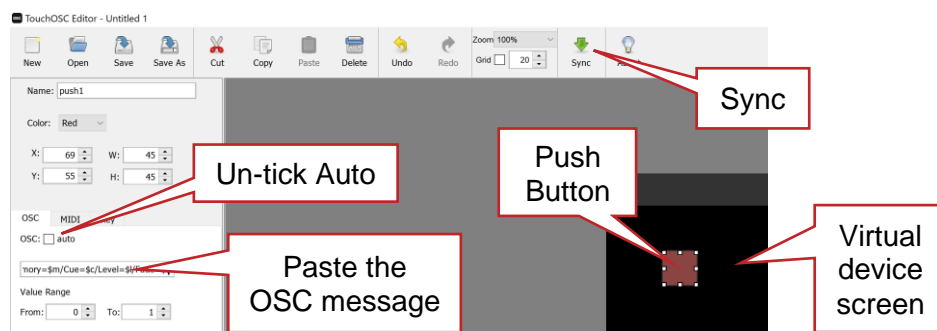

### Touch OSC Editor

In the OSC tab, un-tick the “Auto” box then click in the message box and enter the OSC message that was copied earlier from the Mantra Lite. In the message, replace each of the “\$variables” with the actual variables that you require for the OSC message.

For example:

The copied OSC message is,

`/PlayMemory/Page=$p/Memory=$m/Cue=$c/Level=$l/Fade=$t`

To play Page 1, Memory 2, Cue 3 at a level of 100% with a fade time of 0 seconds, replace the variables with the required values,

`/PlayMemory/Page=1/Memory=2/Cue=3/Level=100/Fade=0`

A label for the button can be inserted by right clicking on the virtual device screen and selecting “Label H” (Label Horizontal) then entering “Text” for the label.

Save the layout and take note of the file name. This is the name that you will later select in the Touch OSC App.

Connect the computer running the Touch OSC Editor and the phone (or tablet) running the Touch OSC App to the same Wi-Fi as the Mantra Lite.

In the “Touch OSC App” select “Layout”, “Add”.

In the “Touch OSC Editor” touch “Sync”.

The layout will be transferred to the App via Wi-Fi.

*Hint: If the transfer does not automatically work, in “Add Layout” select “Edit” then “+”. Enter the IP address of the Wi-Fi.*

In the “Touch OSC App” select “Layout”, then select the layout name that you created in the “Touch OSC Editor”. Select “Done”. The layout appears on the screen of the phone or tablet. Touch the button that you created to send the OSC remote trigger via Wi-Fi to the Mantra Lite.

## 17 Show Files

### 17.1 Overview

Recorded memories (cues and cue-lists), rig view and the patch can be saved and recalled from the internal memory or they can be exported or imported from a USB memory stick. The file is known as a “show” and each show can be individually named.

A “default show” can also be recorded and recalled as a basis for a new show. See section 19.5

The current show name is shown in the top right corner of the home screen.

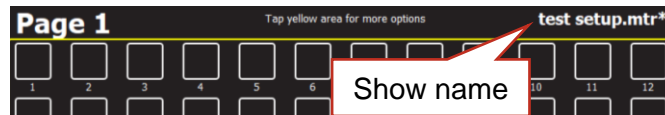

An \* after the show name indicates that the current show has been changed but has not been saved.

Network settings, screen brightness and language are not saved or recalled by show files but are stored internally.

### 17.2 New Show

To open a new show, from the “Home” screen tap **Tools, New Show**. This will clear all memories and clear the patch. If a “Default” show has been saved, “New Show” changes to become **New Show + Default Patch**. See section 19.5 for more details about “Default Show”.

### 17.3 Save Show

To save a show, from the “Home” screen tap **Tools, Save Show**.

- If you are saving a “New Show”, touch in the “File Name” box then enter a name for the show.
- If you are saving an already saved show, the existing show will be updated.

### 17.4 Save Show As

To save an existing show with a new name, from the “Home” screen tap **Tools, Save Show As**. By default, the existing show name will be automatically entered with “\_copy” added to it. You can accept the name or touch in the “File Name” box then enter a new name for the show.

*Hint: It is good practice to regularly save your show with a new name such as “Wednesday Morning” or “Wednesday Afternoon” or “Final Rehearsal”, so if you make a mistake or change your mind it’s easy to go back to a previous version.*

### 17.5 Load Show

When you “Load” a show you replace the entire contents of the Mantra Lite memory with the show data that you load. This includes all Cues and the Patch.

To load an existing show, from the “Home” screen tap **Tools, Load Show**. Touch the show name then touch **Load**.

### 17.6 Export Show to USB

You can export a saved show to a USB stick. The USB stick must be formatted as FAT32. Insert a USB stick in one of the USB sockets on the rear panel. From the “Home” screen tap **Tools**,

**Export Show.** The screen offers the current show name but you can choose a different show if you desire. Touch Save to complete the export.

### **17.7 Import Show from USB**

You can import a previously exported show from a USB stick. Insert a USB stick containing the show file in one of the USB sockets on the rear panel. From the “Home” screen tap **Tools**, **Import Show**. Select the **show file** by touching it. Tap **Load**.

## 18 Mantra Editor Software

### 18.1 Overview

The Mantra Editor programming software can be used to in two ways.

- To off line edit Mantra Lite show files. See section 18.3.
- To on line edit a Mantra Lite show file and remotely take control of the Mantra Lite output. See section 18.4.

The Mantra Editor includes all of the Mantra Lite features such as the fixture library, colour pickers, cue lists and chases plus effects such as animations and shapes. Some features of the editor such as the real time scheduler only apply to the Mantra Mini. The Mantra Mini is a playback unit designed for permanent installations.

### 18.2 Installing the Mantra Editor Software

The Mantra Editor software is available from “mantramini.lsccontrol.com.au”. Download and run the Mantra Editor Setup program on your computer or tablet.

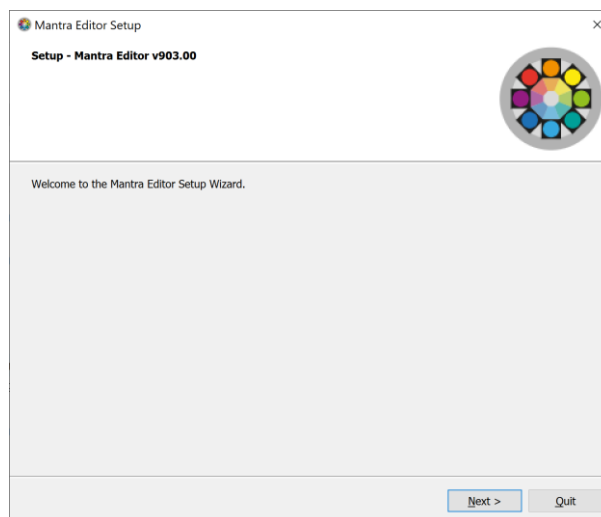

Follow the on-screen instructions and be sure to allow Mantra Editor access through your computers firewall. Run the Mantra Editor program.

### 18.3 Off Line Edit a Mantra Lite Show

Shows exported from a Mantra Lite console can be imported into the Mantra Editor, edited and then exported back to the Mantra Lite. A Mantra Lite show file contains the recorded memories (cues and cue-lists), the patch and the rig view.

#### 18.3.1 Export a Show from Mantra Lite

To export a show from the Mantra Lite to a USB memory stick (formatted as FAT32) insert the USB stick in one of the USB sockets on the rear panel of the Mantra Lite.

From the Mantra Lites “Home” screen tap **Tools, Export Show**. The screen offers the current show name but you can choose a different show if you desire. Touch **Save** to complete the export.

#### 18.3.2 Import a Show into Mantra Editor

Insert the memory stick containing the show file into the computer running the Mantra Editor. To import a show into the Mantra Editor, from the editors “Home” screen tap **Tools, Import Show**.

This opens your computers file manager allowing you to navigate to the USB memory stick and load the show.

When a show has been loaded in the Mantra Editor, the show name is shown in the top right corner of the home screen.

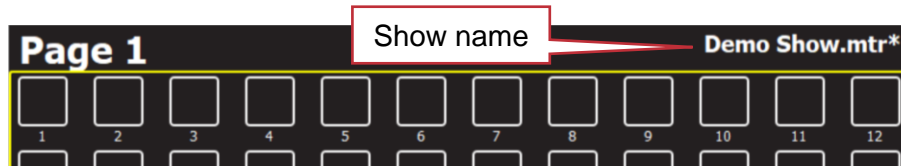

If you make changes to the show file, an \* after the show name indicates that the current show has been changed but has not been saved.

See section 18.5 for details on how to use the Mantra Editor to edit a show.

### 18.3.3 Export a Show from Mantra Editor

A show file in the Mantra Editor can be exported to a USB memory stick. From the Mantra Editor “Home” screen tap **Tools, Export Show**. This opens your computers file manager allowing you to save the show in any location including a USB memory stick. The USB stick must be formatted as FAT32.

### 18.3.4 Import a show into the Mantra Lite

To import a show into the Mantra Lite from a USB memory stick, insert the USB stick in one of the USB sockets on the rear panel of the Mantra Lite.

From the Mantra Lite “Home” screen tap **Tools, Import Show**.

## 18.4 On Line Edit a Mantra Lite Show

A computer running the Mantra Editor program can be used to on line edit a show file. When connected to the Mantra Lite, the Mantra Editor takes control of the Mantra Lite output allowing it to playback the cues in the show and also control the fixtures. The cues can be edited and saved back to the Mantra Lite. The Mantra Editor computer is connected to the Mantra Lite via the Ethernet connector.

The Mantra Editor takes control of the Mantra Lite output whenever the Mantra Editor,

- Loads a show file from the (Remote) Mantra Lite
- Saves a (Local) show file to the (Remote) Mantra Lite

*Hint: The Mantra Editor refers to the show files stored on the computer as “Local” and those stored on the Mantra Lite as “Remote”.*

When the Mantra Editor is in control, the faders, buttons and touch screen of the Mantra Lite do not operate. All control is via the Mantra Editor. See section 18.5 for more details on how the Mantra Lite output is controlled.

When the Mantra Editor is disconnected, the Mantra Lite takes back control of its output and operates normally. The Mantra Editor is disconnected from the Mantra Lite when any of the following are performed,

- A show is saved to the (Local) Mantra Editor
- A show is loaded from the (Local) Mantra Editor
- A “New Show” is opened in the Mantra Editor
- The Mantra Editor program is closed

### 18.4.1 Connecting the Editor to the Mantra Lite via Ethernet

The Mantra Lite default ethernet setting is DHCP (Dynamic Host Configuration Protocol). DHCP is used to automate the process of configuring devices on IP networks. In order to have a network address automatically assigned to the Mantra Lite it must be connected to a DHCP server. Most consumer routers are set up to act as a DHCP server and will automatically assign an IP address to the Mantra Lite. Connect the Mantra Lite and the computer running the Mantra Editor to the same DHCP router.

If a DHCP router is not available you can set a static IP address in the Mantra Lite and in the computer then make a direct network connection.

When using Microsoft Windows to connect to a Mantra Lite, you must set your computers network profile to “Private”. To change the network profile for a wired network, click **Start, Settings, Network & Internet, Ethernet**, then click your network adapter and choose the “Private” profile.

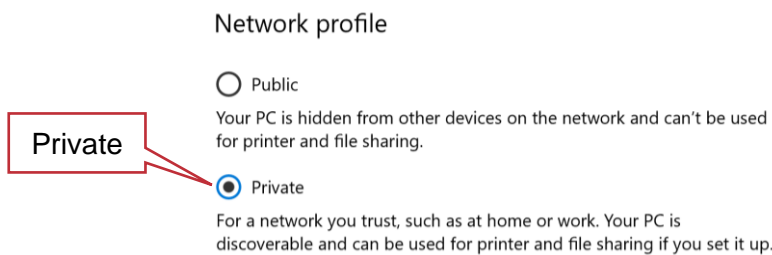

Follow these steps to connect the Mantra Editor to the Mantra Lite via ethernet using DHCP.

1. Connect the Mantra Lite and the computer or tablet running the Mantra Editor to the same DHCP server.
2. Open the Mantra Editor program. To use the ethernet connection, click **Tools, Setup, System Settings**. In the “Available Networks” pane click on **Ethernet** then double click **Back/Home**.
3. To load, control and edit a show that exists on the Mantra Lite, in the Mantra Editor click **Tools, Load Show, View Remote**. Click the Mantra Lite **icon** then click on the show file name then click **Load**. The editor now controls the output of the Mantra Lite.

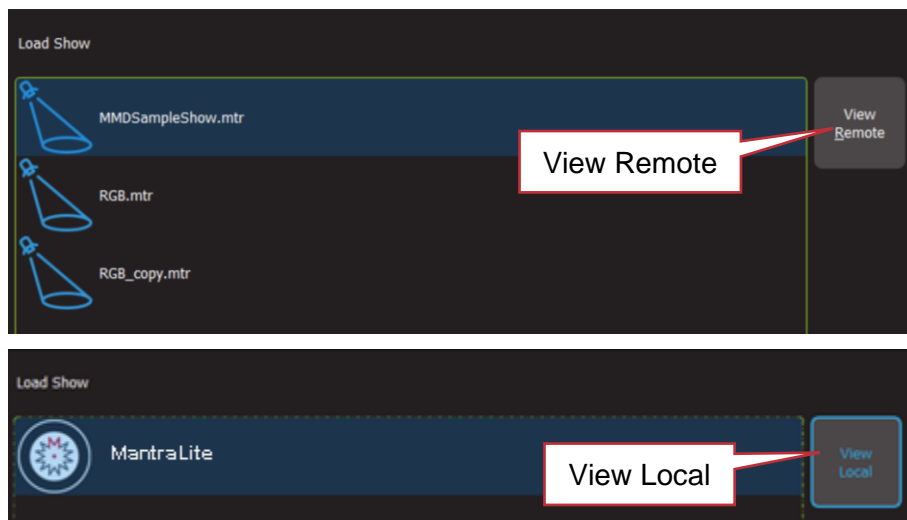

### 18.4.2 Connecting the Editor to the Mantra Lite via Wi-Fi

The Mantra Lite does not have inbuilt Wi-Fi so you must connect its ethernet to a Wi-Fi router. The computer running the Mantra Editor is then connected to that same router via Wi-Fi.

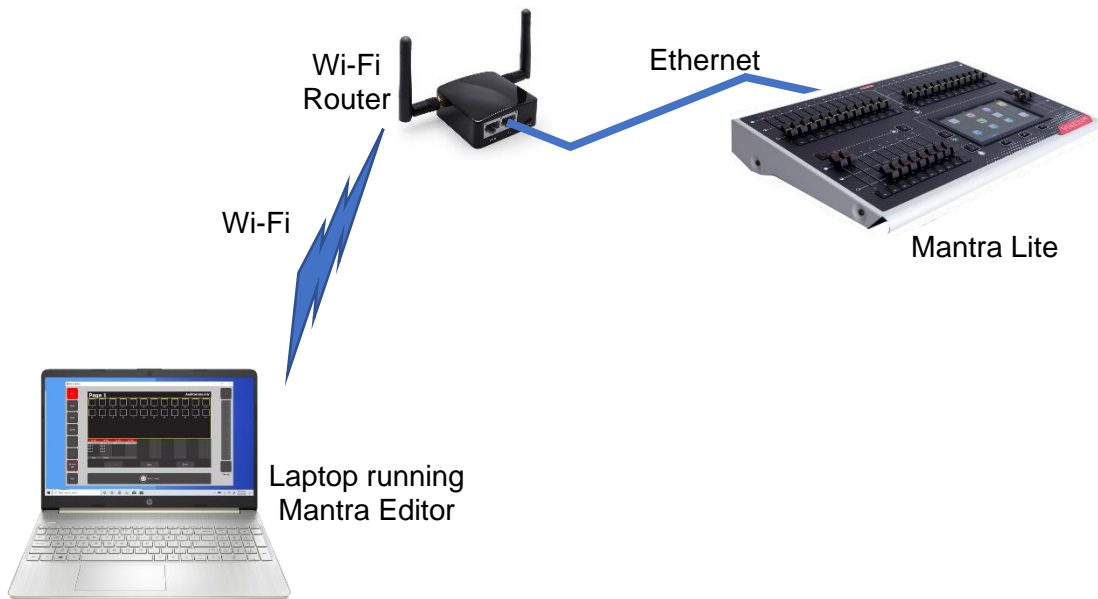

Follow these steps to connect the Mantra Editor to the Mantra Lite via Wi-Fi.

1. Connect a network cable from the Mantra Lite “Ethernet” connector to the Wi-Fi router. Connect the computer or tablet running the Mantra Editor to Wi-Fi signal from the Wi-Fi router.

When using Microsoft Windows to connect to Wi-Fi, you must set your computers network profile to “Private”.

After connecting you might see the following message.

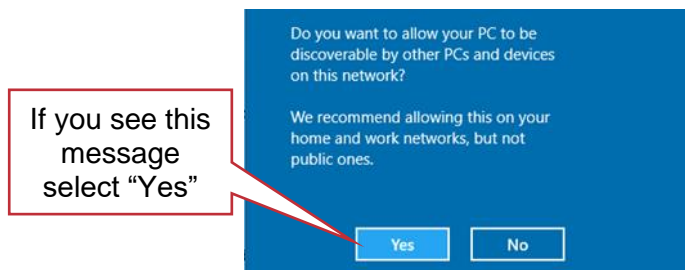

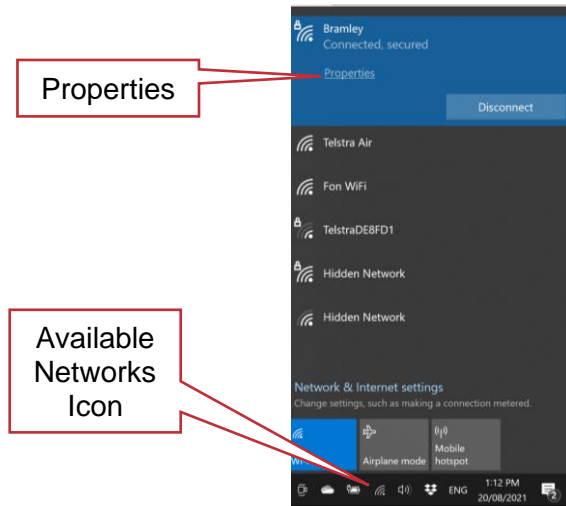

Select “Yes”.

Alternatively, to manually change the network profile to “Private”, click the available Network icon in the Notification area.

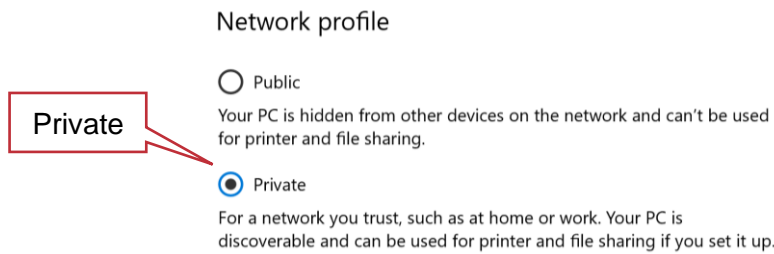

Select the Wi-Fi network and then click **Properties** and in the “Network profile” that opens select **Private**.



2. With the computer now connected to the Wi-Fi, open the Mantra Editor application on your computer. To use the Wi-Fi connection, click **Tools, Setup, System Settings**. In the “Available Networks” pane click on **WiFi** then double click  **Back/Home**.
3. To load, control and edit a show that exists on the Mantra Lite, in the Mantra Editor click **Tools, Load Show, View Remote**. Click the Mantra Lite **icon** then click on the show file **name** then click **Load**. The editor now controls the output of the Mantra Mini.

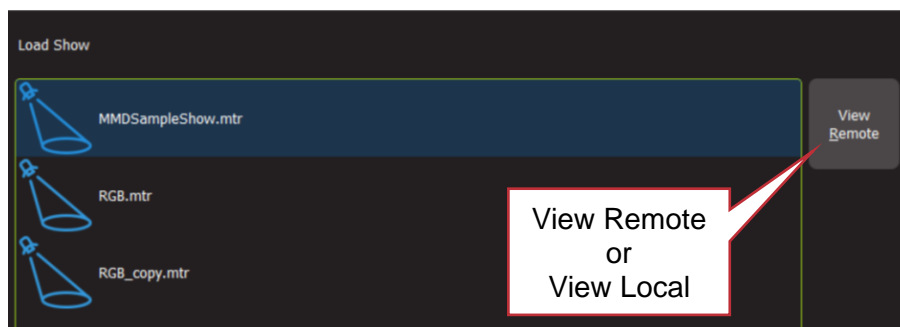

*Hint: When the Mantra Editor is connected to the Mantra Lite, the top of the home screen on the Mantra Editor shows the Network Name of the Mantra Lite followed by the show name.*



*In this example, the Mantra Lites “Network Name” has been set to “MantraLite”. When the Mantra Editor is connected to the Mantra Lite, “MantraLite:::/” is shown before the show name.*

*When the Mantra Editor is NOT connected to the Mantra Mini, only the show name is shown.*



### 18.4.3 Output Priority

The Mantra Lite consists of a fixture faders & playback faders section and an output section.

The “output” section generates the DMX, sACN or ArtNet output signals that control the lighting fixtures. The data that generates the DMX, sACN and ArtNet output signals can come from 2 different sources that are selected by the “automatic switch” as described below.

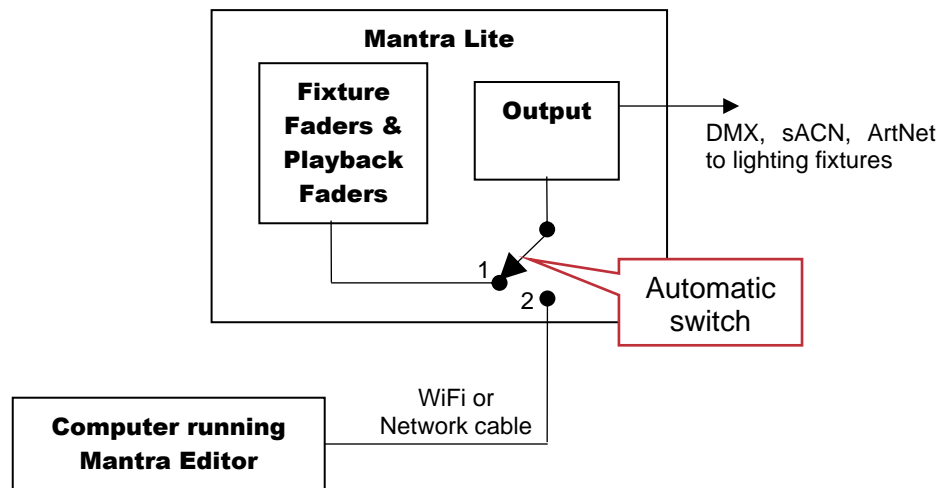

#### “Simplified” Output Signal Sources

1. During normal operation (when the Mantra Editor is not connected), the automatic switch is in position 1 and the “Fixture Faders & Playback Faders” section of the Mantra Lite is connected to the “Output” section and controls the connected fixtures.

2. When a computer or tablet running the Mantra Editor is connected to the Mantra Lite and a show file is either saved to or is loaded from the Mantra Lite, the automatic switch moves to position 2 and the Editor is connected to the “Output” section and controls the connected fixtures. When the Mantra Editor is disconnected, the switch automatically moves back to position 1.

### 18.4.4 Disconnecting the Editor from the Mantra Lite

The Mantra Editor is disconnected from the Mantra Lite when any of the following are performed,

- A show is saved to the (Local) Mantra Editor
- A show is loaded from the (Local) Mantra Editor
- A “New Show” is opened in the Mantra Editor
- The Mantra Editor program is closed

## 18.5 Mantra Editor Controls

Unlike the Mantra Lite, the Mantra Editor does not have any faders or buttons so it uses slightly different techniques to control fixture intensity and to control cue playback. This section describes the different methods used by the Mantra Editor and assumes that you have a working knowledge of the Mantra Lite console as described elsewhere in this manual.

### 18.5.1 Keyboard Shortcuts

Many functions of the Mantra Editor can be performed by a computer keyboard shortcut button. Shortcuts differ depending upon the current screen that is displayed in Mantra Editor. You can experiment to find buttons that work as shortcuts on the various screens.

The following are some of the most useful shortcuts.

- To go back one screen press **Esc** (equivalent to **Back/Home**)
- To clear All fixtures in the “Live memory”, from the Home screen press **A** then **L**
- To turn Off all active cues, from the Home screen press **O**
- To open the Apps screen, from the Home screen press **A**
- To save the show (Tools/Save), from the Home screen press **T** then **S**

### 18.5.2 Editor Main Screen

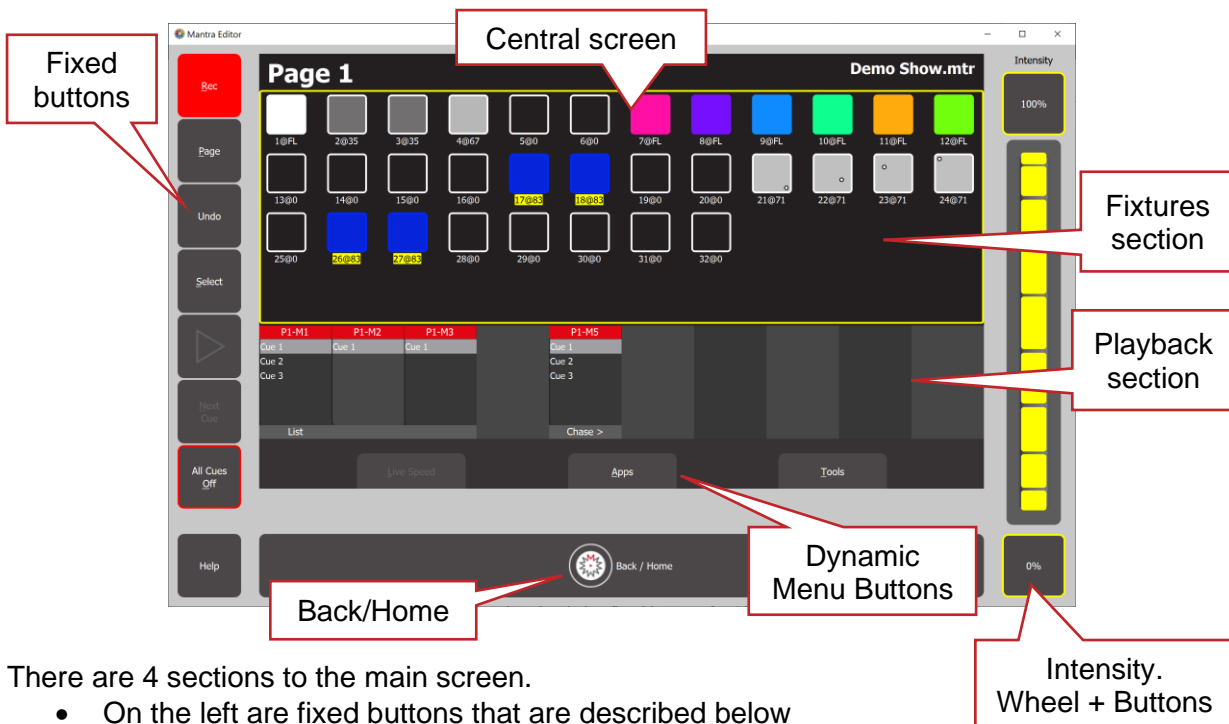

There are 4 sections to the main screen.

- On the left are fixed buttons that are described below
- On the right is the Intensity wheel plus fixed buttons for 0% and 100% intensity
- The central screen emulates the touch screen of the Mantra Lite. It displays the various screens that can be selected by the dynamic menu buttons at the bottom or the fixed buttons on the left.
- At the bottom is the **Back/Home** button.

Some screens have sliders to adjust values. When you click on a slider you can drag the slider and even let the mouse drift off the slider as long as you keep the mouse button down. If you click on the background area of the slider it will snap to your position.

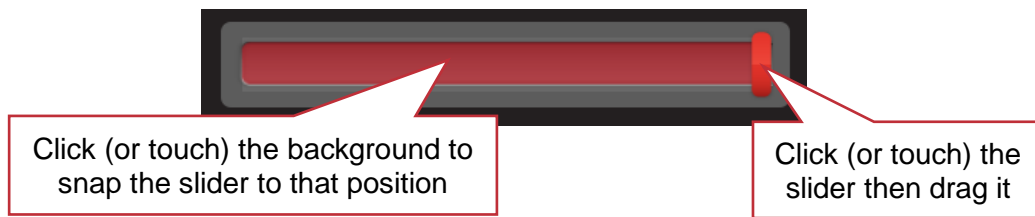

You can also hover the mouse over the slider then scroll the mouse wheel.

*Hint: All events are triggered when you release the mouse button (or lift your finger from a touch screen).*

Just like the touch screen of the Mantra Lite, the top section of the “Home” screen has an icon for each of patched fixture.

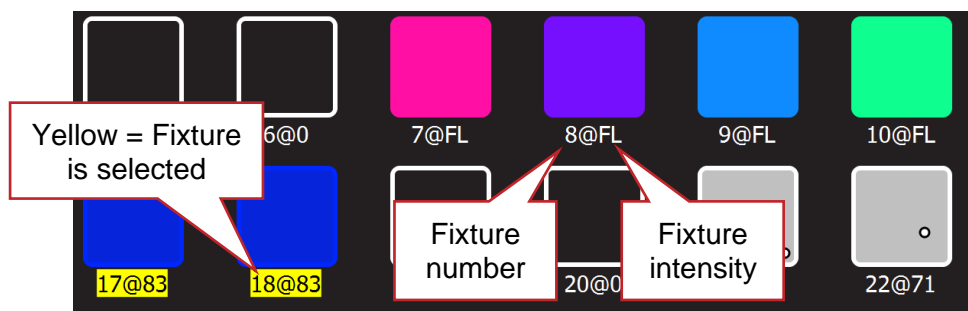

### Fixture Icons

- Below each fixture icon is its fixture number and its intensity (FL=Full)
- “Selected” fixtures numbers have a yellow background

#### 18.5.3 Selecting Fixtures.

Clicking a fixture icon selects that fixture (its number background turns yellow) allowing its intensity to be controlled (see below) and its other attributes (colour, position etcetera) to be controlled by clicking **Apps**.

Click a selected fixture again to de-select it.

You can also select fixtures by clicking the **Select** button. See below.

#### 18.5.4 Controlling Intensity

To the right of the screen are the intensity controls. They become active whenever a fixture(s) is selected. To control the intensity of the selected fixture(s) either,

- Click and drag the “Intensity” wheel
- Hover your mouse above the intensity wheel and scroll the mouse wheel
- Click the 100% or 0% buttons
- Press the computers’ ↑ (up) key to increase intensity by 1%
- Press the computers’ ↓ (down) key to decrease intensity by 1%
- Press the computers’ PgUp (page up) key to increase intensity by 10%
- Press the computers’ PgDn (page down) key to decrease intensity by 10%

#### 18.5.5 Fixed Buttons

The buttons on the left of the screen are:

##### **Rec**

The same as the button on the Mantra Lite.

To record the current output, click **Rec** then click the Playback displayer of your choice (1-10). Flashing red boxes indicate that a recording can be made. To record a cue-list, create the next lighting look on the output then record to the same Playback number.

**Page**

The same as the button on the Mantra Lite. Repeated clicks of the **Page** button will step through the 10 pages of playback memory.

**Undo**

The same as the button on the Mantra Lite. Double click to undo the last action.

**Select**

The same as the button on the Mantra Lite. This opens the “Select” screen which provides another means of selecting fixtures including a list of previous selections, selecting a range of fixtures and reversing the selected order.

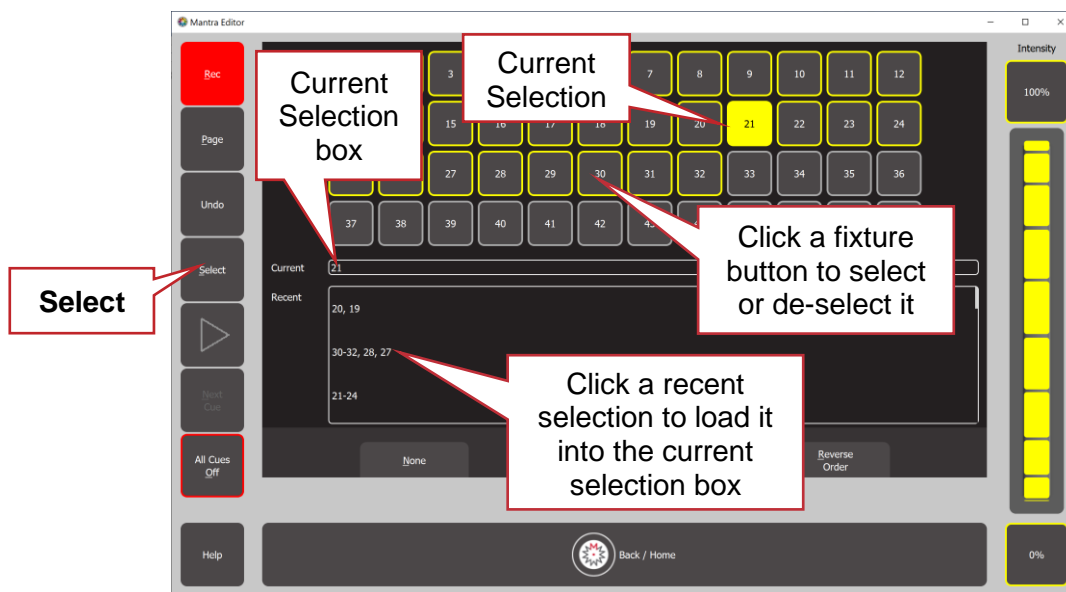

If a playback displayer contains a cue or cue-list, clicking that playback’s displayer opens its “Edit memory” screen and activates the **▶** and **Next Cue** buttons.

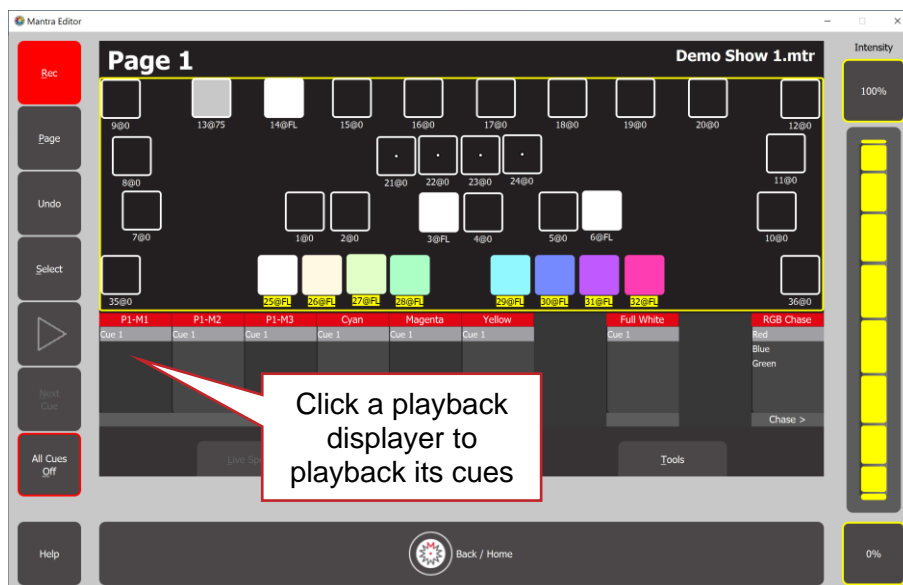

## ► and Next Cue

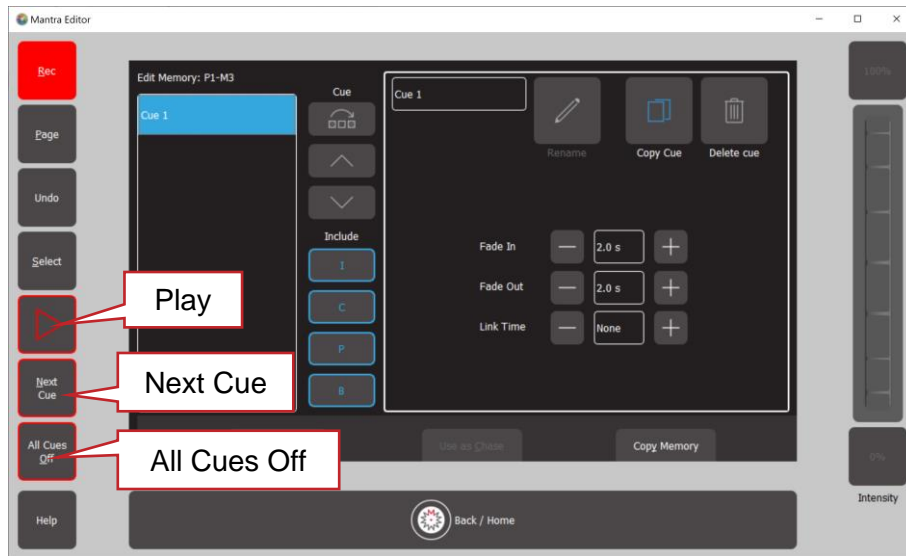

Clicking ► (Play), fades the cue (or cue-list) up or down.  
Clicking **Next Cue**, crossfades to the next cue in the cue-list.

*Hint:* If you want to edit a cue, it is good practice to ensure that the only output you see is the playback that is being edited. To achieve this, firstly clear the live memory by clicking **Apps**, **Clear All** (keyboard shortcut **A** then **L**) then fade down any active playbacks by clicking **All Cues Off** (keyboard shortcut **O**). Now play back the cue to be edited.

### All Cues Off

Up to 100 playbacks (10 playbacks x 10 pages) can be active (faded up) at the same time. If you have multiple playbacks active across multiple pages it can be time consuming to individually select each playback and fade it down. To fade down all active playbacks click **All Cues Off**

### 18.5.6 Apps

Mantra Editor uses the same “Apps” as the Mantra Lite to control the attributes (colour, pan/tilt, shutter etcetera) of the selected fixtures. From the “Home” screen clicking **Apps** (or keyboard shortcut **A**) opens the “Apps” screen.

### 18.5.7 Edit (Update) a Cue

To edit the intensity, colour, position or beam attributes of a fixture in a cue, perform the following steps:

1. Clear all current output by clicking **Apps**, **Clear All** and **All Cues Off**
2. Play the cue to be edited
3. To edit the intensity of a fixture, select the fixture then move the Intensity wheel. When the wheel level matches the level in the cue, the wheel will take control of the intensity. Set the intensity to the required level.
4. To edit colour, position or beam attributes of a fixture, select the fixture(s) then use the appropriate App (colour, position or beam) to make the change.
5. To update the cue, click **Rec** then **click and HOLD** (for 1 second) the playback display which contains the cue. The cue will be overwritten with the edited values.

### 18.5.8 Edit Animations and Shapes

Recorded animations and shapes cannot currently be edited. If you need to change an animation or shape recorded in a cue, create a new animation or shape then overwrite the existing cue by

clicking **Rec** then **click and HOLD** (for 1 second) the playback displayer which contains the original cue.

### 18.5.9 Mantra Mini Overview

The Mantra Editor can also be used to program the Mantra Mini which is a playback unit designed for permanent installations. It takes the Mantra Lite console and packages it as DIN rail mount DMX playback controller that can replay any show from a Mantra Lite console or something new recorded via the Mantra Editor programming software.



**Mantra Mini**

## 19 Setup

### 19.1 Overview

To select the “Setup” screen, from the “Home” screen touch **Tools/Setup**.

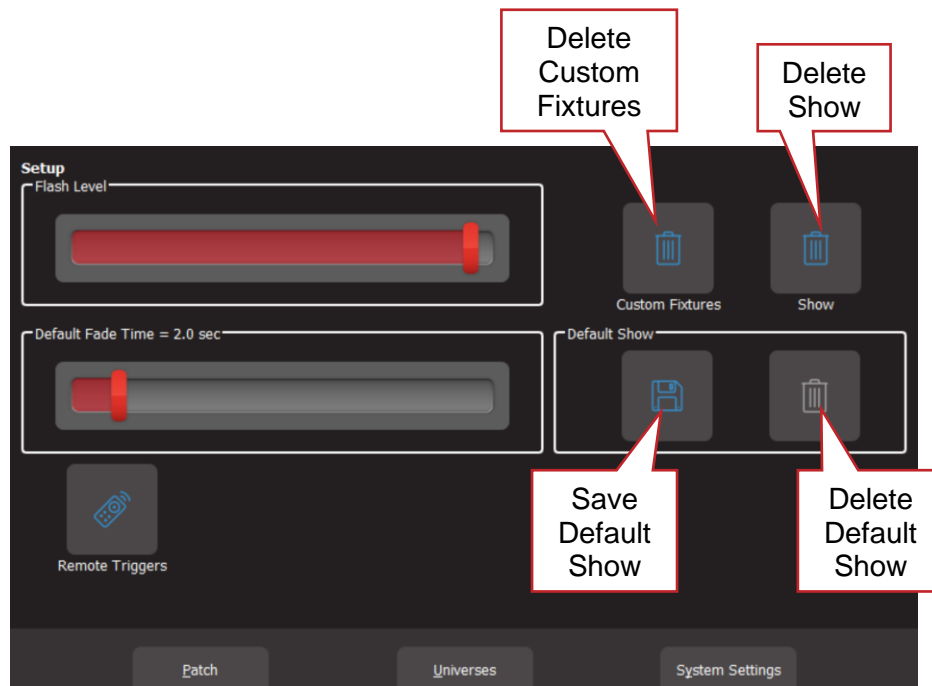

### Setup

The Setup screen offers the following functions:

- Flash Level. See section 15.1
- Default Fade Time. See section 19.2
- Delete Custom Fixtures. See section 19.3
- Delete Show. See section 19.4
- Save Default Show. See section 19.5
- Delete Default Show. See section 19.6
- Remote Triggers. See section 16
- Patch. See section 4
- Universes. See section 4.12
- System Settings. See section 19.7

### 19.2 Default Fade Time

When a cue is recorded, the “Fade In” and “Fade Out” times will be the time value in the “Default Fade Time” setting. To change the default fade time setting, from the “Home” screen touch, **Tools, Setup** then use the “Default Fade Time” slider.

### 19.3 Delete Custom Fixtures

You can delete the entire custom fixture library. These are fixtures templates created by you using the Fixture Editor.

To delete all custom fixture files, from the “Home” screen touch, **Tools, Setup, (Trash Can) Custom Fixtures, Yes**.

All custom fixtures are saved in any show to which they are patched, so after deleting the custom database, reloading shows containing custom fixtures will automatically add those fixtures back into the now empty database.

## 19.4 Delete Show

To delete a show file, from the “Home” screen touch, **Tools, Setup, (Trash Can) Show**. All saved shows are displayed. Touch the icon of the show to be deleted than touch Delete. To confirm the action touch **Yes**.

*Note: Deleting a show cannot be un-done.*

## 19.5 Save Default Show

If a default show does not exist, selecting a “New Show” will delete the patch and all memories. If your Mantra Lite is to be used in a permanent installation or in a touring setup where you regularly use the same patch then LSC recommends that you create and save a “default show”. The “Default” show includes the patch, your rig view arrangement and any cues that you choose to include. If a “Default show” has been saved it will be automatically loaded whenever you select a “New Show + Default Patch” so that you do not need to re-patch your fixtures. When you save a default show you can choose to “PIN Protect” it so that it cannot be easily changed or deleted.

To save a “Default” show, ensure that your patch is correct then from the “Home” screen touch **Tools, Setup, Save Default Show**. You will be asked if you want to PIN protect the default show. If you answer “Yes” you must enter a 4-digit PIN.

### 19.5.1 Default Show Emergency PIN

If you have forgotten your PIN for the default show you can always access it with the emergency PIN 3175.

## 19.6 Delete Default Show

To delete the “Default” show, from the “Home” screen touch **Tools, Setup, (Trash Can) Default Show**. If the default show is PIN protected you must enter your PIN to delete the show.

## 19.7 System Settings

To select the “System Settings” screen, from the “Home” screen touch **Tools, Setup, System Settings**.

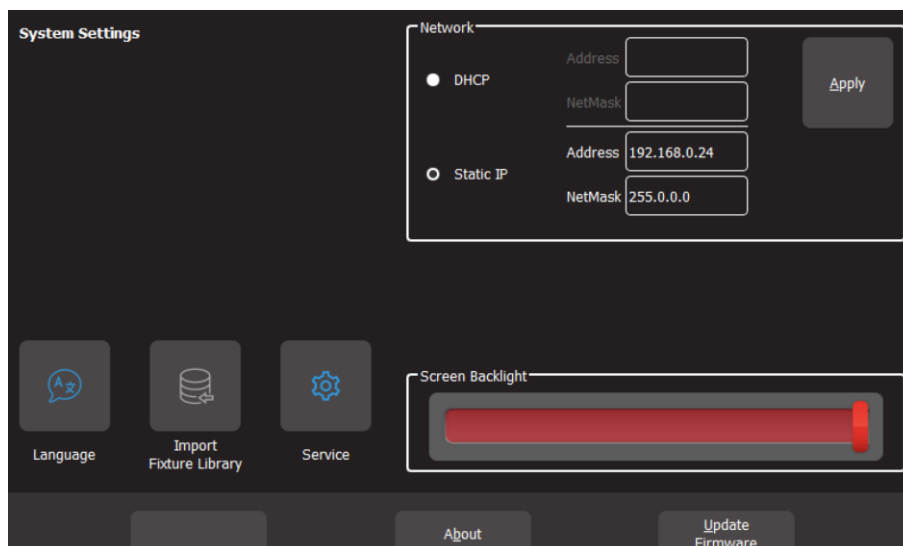

**System Settings**

### 19.7.1 Network

The ETHERNET connector on the rear panel can be used for multiple purposes.

- Transmit ArtNet and sACN lighting protocols that support multiple DMX universes over Ethernet. See section 4.12 for details on how to assign the output to an ArtNet or sACN universe.
- Remotely control playback by using “Remote triggers”. See section 16 for details.

You can have a network address automatically assigned by the network or you can manually enter an address.

- To have a network address automatically assigned select **Tools, Setup, System Settings**, then in the “Network” box touch **DHCP**. Use this setting when connecting to the internet.
- To manually enter a network, select **Tools, Setup, System Settings**, then in the “Network” box touch **Static IP** and enter the Address and Net Mask. Use this setting when streaming ArtNet or sACN over a dedicated lighting network.

When Mantra is only connected to your lighting rig network, LSC suggests that you use the following “Static IP” settings in Mantra:

- Address: 2.0.0.1
- Net Mask: 255.0.0.0

Set every other device on you lighting network to a different address. For example:

- 2.0.0.2
- 2.0.0.3
- etcetera.

### 19.7.2 Language

See section 3.1.1

### 19.7.3 Import Fixture Library

In the Patch menu you tell Mantra Lite the manufacturer/model and DMX address of each of fixture it is controlling. Mantra Lite then loads a “template” for that manufacturer/model of fixture from its fixture library. The template tells Mantra Lite how to control that fixture.

The Mantra Lite uses the Carallon fixture library. This provides over 5,500 fixtures, most with multiple operating modes, all included as standard with the console. Updates for this library are released from time to time by LSC and can be downloaded and imported into Mantra Lite.

To update the fixture library, perform the following steps,

1. Download the latest Mantra Lite fixture library from [Iscontrol.com](http://Iscontrol.com)
2. Create a folder named “LSC” on a blank USB memory stick
3. Copy the library file into the “LSC” folder on the USB stick
4. Insert the USB Stick into the Mantra Lite
5. From the “Home” screen touch **Tools, Setup, System Settings, Import Fixture Library**
6. Reset the Mantra Lite by pressing and HOLDING the following 3 buttons for 0.5 seconds.  **(Back) + Undo + Help**

*Note: Mantra Lite software updates also include the latest version of the fixture library.*

### 19.7.4 Service

No user functions are in this menu. It is for factory use and is PIN protected.

### 19.7.5 Touch Screen Backlight

To adjust the brightness of the touch screen, from the “Home” screen touch, **Tools, Setup, System Settings** then use the “Screen Backlight” slider.

### 19.7.6 About

LSC has a policy of continuous improvement of its products. As the Mantra Lite is a computerised lighting desk, its software is subject to this policy as new features are added and existing features improved.

To display the software version in your Mantra Lite, from the “Home” screen touch **Tools, Setup, System Settings, About**.

### 19.7.7 Update Firmware (Software)

#### IMPORTANT

Software version 4 (and above) incorporates a major change to the underlying operating system of the Mantra Lite. This allows many new powerful features to be added. The majority of Mantra Lite consoles can be upgraded, however the v4.x software will **NOT** run on very old Mantra Lite consoles because their CPU (Central Processing Unit) is not compatible. Installing it will render the console unusable and may require it to be returned to an authorised LSC service agent to recover it and you will be charged for their labour.

To check the compatibility of your Mantra Lite, on the touch screen, navigate to;  
**Tools, Setup, System Settings, About.**

The “About” screen must contain the words:

CPU : Model 3 (or better).

For example,

Model 3A

Model 3B v1.2

If the screen contains the words “CPU : Model 2”, you must **NOT** install this software. Contact your local LSC dealer for information and pricing on upgrading your console’s CPU to the latest version.

To install a software update, perform the following steps,

1. Download the latest Mantra Lite software from [lscighting.com](http://lscighting.com)
2. Create a folder named “LSC” on a USB memory stick
3. Copy the software file (file named mantra\_v1.nn.img where ‘nn’ is the software version number) into the “LSC” folder on the USB stick
4. Insert the USB Stick into the Mantra Lite
5. From the “Home” screen touch Tools/Setup/System Settings/Update Firmware
6. If your current show has unsaved changes, you will be prompted to save
7. The update process takes about 20 seconds
8. Once complete you will be prompted to restart Mantra Lite
9. Reset the Mantra Lite by pressing and HOLDING the following 3 buttons for 0.5 seconds.  **(Back) + Undo + Help**

## 20 Feature History

The new features added to Mantra Lite in each software release are listed below:

Release: v4.01

### IMPORTANT

The v4.x software will NOT run on very old Mantra Lite consoles. See section 19.7.7

Multi Intensity fixture control. The Mantra Lite now provides enhanced support for fixtures with multiple intensity channels. In the past the control of multiple intensities was only supported for fixtures that had a master intensity channel. V4.01 software now supports all fixtures with multiple intensity channels, regardless of whether they provide a master/global intensity parameter. The Multiple Intensity parameters now appear in their own 'Sliders' App, located in the Intensity column of the Apps screen. Previously they appeared in the Beam column's 'Other' App. The yellow fader now acts as a master intensity over the multiple intensities.

Release: v4.00

### IMPORTANT

The v4.x software will NOT run on very old Mantra Lite consoles. See section 19.7.7

Extended Colour Mixing. The colour picker now controls all colour mix colours, including Lime, Amber, Cyan, Royal Blue, etc. The White parameter continues to be controlled by the vertical movement of the selection cursor.

Enhanced Colour Sliders. Colour sliders now include a subtle colour band above the fader to graphically indicate the colour they control.

HSI colour control. The colour picker now supports fixtures that require HSI colour control.

Multi Intensity fixture control. The Mantra now provides enhanced support for fixtures with multiple intensity channels. In the past the control of multiple intensities was only supported for fixtures that had a master intensity channel. The new software now supports all fixtures with multiple intensity channels, regardless of whether they provide a master/global intensity parameter.

The Multiple Intensity parameters now appear in their own App, located in the intensities column of the Apps screen. Previously they appeared in the Beam/Other App.

The yellow fader now acts as a master intensity over the multiple intensities.

Chase Flash function. Previously the button below the Fader of a chase was used for "Tap To The Beat" speed control. Since the introduction of the Live Speed app, this functionality has become less popular. The button below the Fader now operates as a Chaser Flash button. If the fader is at zero, pressing the button will start the chase (always at step 1) and keep it running for as long as the button is held down.

Release: v3.06

A new button in the Setup window has been added to allow the user to delete the entire custom fixture library.

Release: v3.05

No new features. Bug fixes only.

Release: v3.04

No new features. Bug fixes only.

Release: v3.03

This version was never released to the public.

Release: v3.02

The fixture library now contains a version number that is displayed in the About screen allowing you to check if the console has the latest library installed.

The fixture library has enhanced encryption to prevent tampering.

The Colour Picker now controls White in the vertical axis as well as RGB colours. Moving the pointer towards the white section at the bottom of the screen adds white proportionally in addition to the RGB colours.

A "Please Wait" pop-up message now appears during lengthy operations such as show load or fixture library update.

The fixture library used in the Mantra Lite v1.00 thru v1.37 was replaced in v2.0 with the superior Carallon fixture library. To minimise disruptions for existing shows, the old library has been retained to allow existing shows to work without modification. Future versions of Mantra Lite software will include new features that are not compatible with fixtures from the old library. A warning message now appears when a show that contains old fixtures is loaded, asking you to repatch the fixtures using the new library. If this task is not done, then the show will not load in future software versions.

Release: v3.01

This version was never released to the public.

Release: v3.0

Remote Triggers. You can now control the output of the Mantra Lite from other devices such as touch phones or third-party button panels.

New chase patterns of reverse and random added.

Copy memory added.

Name memory added.

Fixture intensity levels are now displayed on home screen.

View DMX output screen added.

Art-Net and sACN output can be set to any universes.

The output can be overridden by an Art-Net or sACN input.

Colour Sliders are now located on the Apps screen. Colour Gels are now accessed from the Colour Picker screen.

The Apps screen can only be selected by tapping the Apps button. Previously Apps could also be accessed by tapping anywhere on the fixture section.

Updated "Select" screen. [Set] button removed.

The free "Mantra Editor" software can be used to edit a show from a Mantra Lite.

The Sample Show does not automatically load on first use.

Release: v2.05

No new features. Bug fixes only.

Release: v2.04

Link times added. Each cue in a cue list now has a Link Time. These are used to allow the next cue to automatically play after the programmed time.

The playback displayer can now be used to record cues. Press the [Record] button and then tap the playback displayer where you want the cue recorded. The old method of pressing [Record] and the button below a red fader still works, users can use whichever method they prefer.

Systems settings are now global. Network settings, screen brightness and language were stored in the show files. They are now stored in a separate configuration file on the console, making them global and independent of the loaded show.

New Systems Setting screen added. Changes have been made to the layout of the Setup window to allow for new features being added for the forthcoming installation version of the Mantra Lite (the Mantra Lite). This has necessitated the addition of a new Systems Settings window and some items have been moved from Setup to the new window.

**Release: v2.03**

Support for new touchscreen hardware. A new touchscreen controller is used in consoles shipped after mid-December 2019. This requires new hardware driver firmware. The firmware auto-detects which controller is installed and activates the correct driver to suit. Installing any software prior to v2.03 will render new consoles unusable as the touch screen will not respond. A one-time warning is issued if the user tries to downgrade the software to an earlier incompatible version.

Improved Playback displayer. The playback displayer now shows the cue/s fading. This is achieved by the red highlight bar 'growing' from the left to the right side of the displayer.

**Release: v 2.02**

This version was never released to the public.

**Release: v2.01**

The underlying operating system has been updated resulting in faster boot times, improved show load/save and easier to read fonts and graphics.

The firmware for the hardware interface has been updated. This reduces jitter on faders and provides smoother fader control. Flash button response is also considerably faster.

You can now patch more than one identical fixture to a yellow fader.

It is now possible to search the fixture library.

It is now possible to set the default fade time.

Mantra Lite now supports non-Latin character sets (e.g. Chinese & Japanese).

A larger easier to read font is now used on the touch screen.

The fixture library now updates in less than 2 seconds.

"QX1" USB to DMX512A adaptor support added.

All colour faders (colour wheels, Cold White, Warm White, etcetera) are now located in the sliders window of the colour picker app.

A cursor has been added to text edit windows for easier editing.

RGB colours of compound (multi-cell) fixtures are now controlled from the colour picker.

**Release: v.137**

No new features. Bug fixes only.

**Release: v1.36**

An 'Are you sure?' screen has been added to the 'delete cuelist' button functionality.

**Release: v1.35**

The bottom left button below the Home screen is now used to access the Live Speed controls. Three encoders are provided for Fade Time, Chase Rate and X-Fade. Other controls allow for configuring whether changes affect all active playback/s (global) or selected playback/s, resetting the adjusted times and setting the sensitivity of the encoders.

The Live Speed controls also features a Tap To The Beat button, to allow easy synchronisation of chase/s to the beat of the music.

The Mantra Lite now uses the Carallon fixture library. This provides over 5,500 fixtures, most with multiple operating modes, all included as standard with the console. A fixture request service is available via the LSC web page, to enable you to request new fixtures for addition to the database. This process takes at least one month from the date of request. If you require an urgent template you can continue to use the inbuilt Fixture Editor.

The Shapes App has two additional shapes (Square and Triangle) and Shapes can now be rotated, to set the apex to any orientation.

**Release: v1.30**

IPCB (Intensity, Position, Colour, Beam) filtering added for playback. Cues are still recorded with all parameters.

Text fields (e.g. CueName) now have all the text highlighted when selected, allowing typing to instantly replace the existing text. Two new buttons on the pop-up keyboard allow the cursor to be moved back and forth in the text edit window.

Show saves are now much faster.

Release: v1.25

No new features. Bug fixes only.

Release: v1.24

No new features. Bug fixes only.

Release: v1.23

The Export function confirmation button is now labelled “Export” instead of “Save”, to avoid confusion.

Help is now available in Dutch.

Release: v1.22

The Software Upgrade process now updates the firmware in the surface and wings.

Fader selection of fixtures is now disabled in the Patch window to allow testing of fixtures that have been patched without re-selecting them.

Additional parameters (e.g. Gobo, Zoom, Focus) have been added to the list in the Fixture Editor to make fixture creation faster.

The Fixture Editor can create fixtures of up to 48 DMX channels with or without Wings connected.

There are now [-1] & [+1] buttons to increment/decrement the selected DMX slot to add the parameter to as well the old method of moving a fader.

Release: v1.21

No new features. Bug fixes only.

Release: v1.2

Expansion Wings are now supported.

A Shapes App allows easy creation of Circles, Fig8, Ballyhoos and other effects on the Pan & Tilt of any moving light.

It is now possible to record a blank cue in a cuelist. This is commonly required at the start and end of a cuelist, to enable a blackout.

Release: v1.11

The crossfade engine for cuelists is now totally Dipless for all parameters.

It is now possible to record a blackout memory.

A [Clear All] button has been added to the Centre soft button on the Apps screen, for quicker access to this feature.

Release: v1.10

Cue Lists and Chases have been added.

The Fixture editor now has a clear function.

Custom fixtures are now saved with the show when it is exported.

The help menu is now available in Italian.

The behaviour of cue fading has changed. Playbacks no longer fade back to the Live (yellow)

Memory when faded out. They now retain their colour, to prevent the colour fading out to white.

Release: v1.05

Fade times on Cues are now possible.

Unwanted Custom Fixtures can now be deleted.

There is now a clear function in the Fixture Editor.

The Fixture Editor now prevents more than one attribute of the same name and type.

Release: v1.04

The Fixture Editor can now load existing fixtures as a starting point for new ones. It can edit existing custom fixtures.

## 21 Fixture Editor

### 21.1 Overview

If you have a new fixture and it is not listed in the Mantra Lite fixture library you can create a template for it, even if you don't know the functions of its DMX channels. The Mantra Lite Fixture Editor allows you to use the yellow faders to directly control the DMX channels of the fixture and hence discover the function of each channel. You then select an attribute name for each channel, then name and save the new template.

You can also use the Fixture editor to edit an existing fixture template. The fixture file that you create is known as a "custom" fixture.

### 21.2 Creating a Fixture Template

In normal operation (not in the "Fixture Editor"), the yellow faders control the intensity of the fixtures that are patched to them. When you open the "Fixture Editor" they change and become individual DMX channel control faders starting from the DMX address that you specify in the editor. For example, if you enter a DMX address of 1 in the fixture editor, yellow fader 1 controls the level of DMX channel 1, yellow fader 2 controls DMX channel 2, yellow fader 3 controls DMX channel 3 etcetera. If you now connect your new fixture to the DMX output of Mantra Lite and set the fixtures DMX address to 1, yellow fader 1 controls its first channel, yellow fader 2 controls its second channel, yellow fader 3 controls its third channel etcetera. You can now use the yellow faders to discover the function of each channel of the new fixture.

To open the Fixture Editor, from the "Home" screen press: **Tools, Setup, Patch, Fixture Editor:**

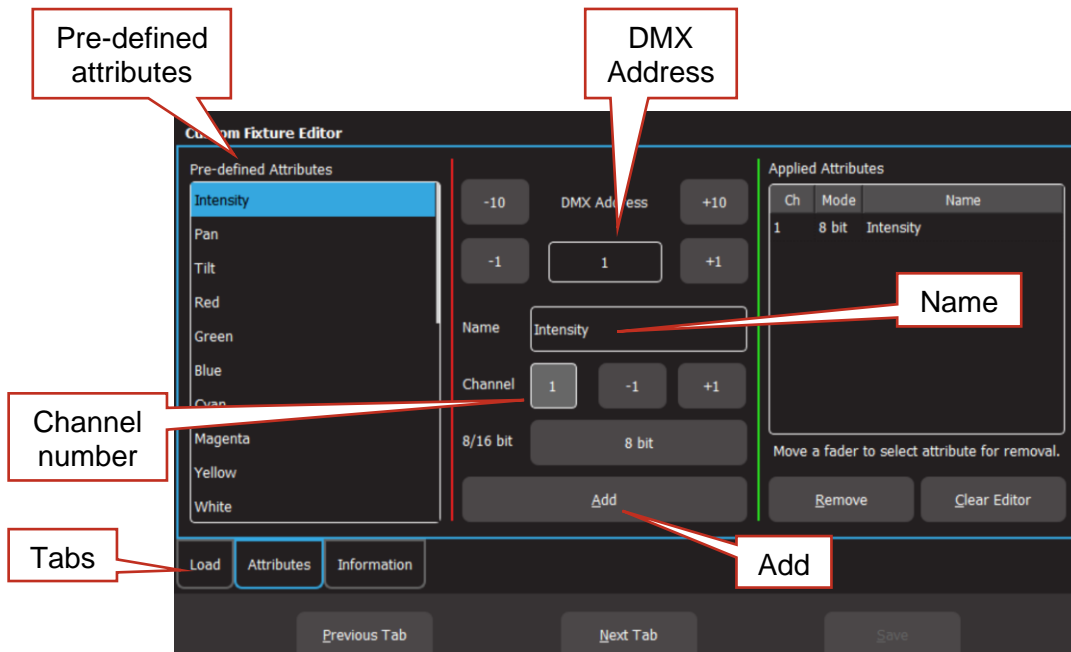

#### Custom Fixture Editor (Attributes Tab)

There are 3 pages that are selected by the "Tabs":

1. Load.
2. Attributes
3. Information

The editor opens on the "Attributes" Tab. Connect the new fixture to the Mantra Lite DMX output. Ensure that the Fixture editor and the new fixture are set to the same DMX address.

Fade up channel 1 fader. When you move a fader, its number is automatically entered in the Channel number box. Observe the operation of the fixture. Which attribute of the fixture is the fader controlling? Select the appropriate Attribute name for this channel from the list in the “Pre-defined Attributes” box. Swipe to scroll the list for more names. If no suitable name exists either choose “Unknown” or touch the “Name” box and enter a descriptive name. To create the attribute for this channel, tap **Add**.

Fade up channel fader 2. Notice that whenever you move a fader, that number is automatically entered into the Channel Number box. Observe the operation of the fixture when you move fader 2 and repeat the above procedure to add the attribute. If an attribute is used for fine control of a function, tap the **8 bit** field. It will toggle to “16 bit”. This automatically sets two consecutive channels as course and fine control respectively. Typically, this will be where 2 channels are used for movement. One channel will be the course control and the other will be for fine.

If you have a fixture that has a fine channel that is not the next consecutive channel after the course channel, then you will need to make a fixture file request to LSC. See section 4.1. In the mean time you might be able to select a simpler mode for the fixture that does not use a fine channel.

If you make a mistake on a channel, move the fader to automatically select it then touch **Remove**.

When all attributes have been identified and added touch **Next Tab** (Information).

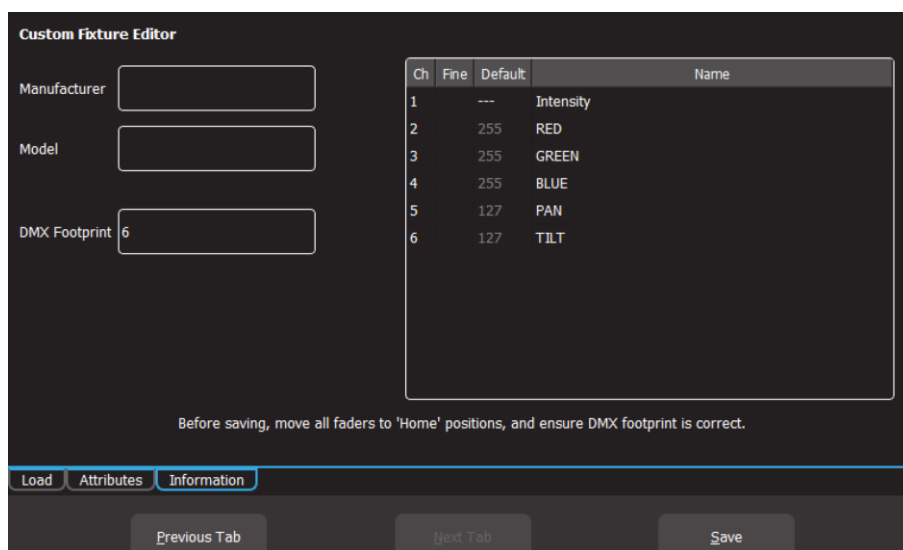

### Custom Fixture Editor (Information Tab)

Enter a Manufacturer and Model name. If you don't know the manufacturers name enter “Unknown” or you can use any name that helps you organise your fixtures. For example, “Gregs Fixtures”.

Check the specifications of the fixture and determine the quantity of DMX channels that it actually uses. This is known as the fixtures “DMX Footprint”. Every time you “Add” an attribute in the fixture editor it automatically increments the count in the “DMX Footprint” field. Some fixtures provide DMX channels for functions that you do not require and hence you might not have added Attributes for these channels. If this is the case you must manually enter the correct number of DMX channels actually used by the fixture in the “DMX Footprint” field. This ensures that Mantra Lite will not overlap DMX addresses when patching multiple fixtures.

### 21.2.1 Home Positions

Home positions for Gobos, Zoom/Focus, colour and shutter/strobe attributes are saved in the template.

- Set all of the faders to the values required for the fixtures “Home” position. The recommended “Home” attribute settings are:
- All Gobos set to open.
- Zoom/Focus at 50%.
- No colour.
- Shutter/Strobe fully open.

*Note: The Intensity, RGB/CMY colours and Pan/Tilt attribute faders are ignored when setting the Home position. These attributes are always set to the same Home values:*

- *Intensity = zero. This is because intensity is always controlled by the yellow fader.*
- *RGB/CMY Colour = white. RGB are at 100% and CMY are at 0%.*
- *Position = centre.*

*So, despite what the fixture information shows for both factory and user created templates, the “default” values for intensity, RGB/CMY and Position (Pan/Tilt) will not be what is shown in the fixture information window nor what is set in the fixture editor.*

All of these Home values are applied to the fixture when the fixture is “cleared”. See section 8.9.

Press **Save** to create the new template. The new template will be listed in the library under the name that you enter in the “Manufacturer” pane. The name that you enter in the “Model” pane will have the word (custom) automatically appended to it to distinguish it from fixtures that were included in the imported fixture library.

*Hint: The fixture library has a manufacturer listing of “Custom”. These are custom fixtures from unknown manufactures included in the imported fixture library and should not be confused with custom fixtures that you create.*

### 21.3 Edit a Fixture Template

If you want to edit an existing fixture, from the “Home” screen press: **Tools, Setup, Patch, Fixture Editor**, then select the **“Load”** tab.

Select the fixture template that you want to edit then touch **Load**.

Edit the fixture settings in the “Attributes” and “Information” tabs as described in section 21.2 and then save the edited template.

## 22 Visualiser

Mantra comes with a “Sample” show that you can load so that you can familiarise yourself with the controls before patching your own fixtures. It is perfect for training and demonstration of the console.

If you would like to see a simulation of the fixtures in the Mantra Lite sample show working on a virtual stage on your computer you can download a 3D visualiser lighting program called “Mantra Lite Visualisation show” from the LSC website.

There are versions for PC and Mac.

*Note: The visualiser programme requires a 3D graphics card with OpenGL support to run. If your computer does not have a compatible graphics card the software will report an error when you run it and it will close.*

If you have changed or deleted the sample show that shipped with the console it can also be downloaded from the LSC website. Save it to a USB stick then insert the stick into the Mantra Lite console and touch **Tools, Import**.

To setup the visualiser, connect a network cable from the Ethernet connector of the Mantra Lite to the Ethernet connector of your computer. See section 2 “Getting Connected”.

Setup the network as follows:

From the “Home” screen touch Tools/Setup/System Setting. The network setting of Mantra Lite need to be set to:

- Static IP
- Address 2.0.0.1
- NetMask 255.0.0.0

Touch **Apply**.

Set the IP address of your computer to:

- Address 2.0.0.2
- NetMask 255.0.0.0

*Hint: If you are unsure how to set the IP address of your computer LSC suggests that you do an internet search.*

On the Mantra Lite, from the “Home” screen touch **Tools, Setup, Start ArtNet**.

Run the visualisation program on your computer. The computer now shows the fixtures in the sample show working on a virtual stage on your screen under the control of your Mantra Lite.

## 23 Troubleshooting

### 23.1 FAQ

Q. Some of my fixtures still have colours selected.

A. Clear the fixtures. From the “Home” screen touch **Apps, Clear**. Select the fixtures to be cleared by tapping their buttons then touch **Colour**.

You can also clear all animations and all attributes of all fixtures. From the “Home” screen touch **Apps, Clear, All** (trash can icon).

Q. Some of my moving fixtures are still moving, even when their yellow the faders are down.

A. Clear the animations on those fixtures. From the “Home” screen touch **Apps, Clear**. Select the fixtures to be cleared by tapping their buttons then in the “Animations/Delete” pane touch **Position**.

You can also clear all animations and all attributes of all fixtures. From the “Home” screen touch **Apps, Clear, All** (trash can icon).

Q. I can't see some of my channels animating on the output.

A. Fade down all red playbacks. One of them might contain some of the channels you are animating and the red playback has precedence.

Q. I can't get any intensity output from some of the yellow faders.

A. There might be an intensity animation still running and it has priority. Delete the animation. From the “Home” screen touch **Apps, Clear**. In the “Animations/Delete” pane, touch **Intensity**. You can also clear all animations and all attributes of all fixtures. From the “Home” screen touch **Apps, Clear, All** (trash can icon).

Q. My animation is running strangely.

A. Animations respect your fixture selection order. Make sure you have selected your fixtures in the desired order. You can see the selection order in the animation App.

Q. I created an animation set to “centre in” but only half the fixtures are animating.

A. Centre in and centre out animations work best with an odd number of fixtures so that the pattern is symmetrical around the centre fixture. If you have an even number of fixtures there is no centre fixture because the centre is the gap between fixtures. You must therefore program a symmetrical static look with at least one different setting on both sides of centre.

Q. I tried to record a cue but the screen said “There is nothing to record”.

A. Recording a cue only includes fixtures that have intensity greater than zero. Fade up the fixtures to be recorded. Also see section 11.5.

Q. I have broken the touch screen.

A. If the touchscreen still displays images correctly you can plug in a USB mouse and use it to make your selections.

### 23.2 Rescue File

In the unlikely event that you have saved a default show and the default show gets corrupted, the console will not be able to load the show at power up, resulting in it failing to start operating. You can restore normal operation by following these instructions:

On a computer with internet access go to the LSC website then navigate to the Mantra Lite software and download the “Rescue File” and save the file onto a USB memory stick.

Turn off the Mantra Lite console.

Plug the memory stick into the Mantra Lite then turn the console back on.

The default show will be deleted, allowing the console to start normally.

Ensure that the USB stick is then removed.

If you were previously using a “Default Show” you should create and save a new one. See section 19.5 for details.

## 24 Specifications

	<b>Mantra Lite</b>	<b>Mantra Lite + 1 Wing</b>	<b>Mantra Lite + 2 Wings</b>
<b>Control</b>	18cm capacitive LCD screen with app-based user interface		
	Direct control of up to 24 fixtures 10 playback masters 100 cue lists/chases, each with a maximum of 250 cues/animations	Direct control of up to 36 fixtures 20 playback masters 200 cue lists/chases, each with a maximum of 250 cues/animations	Direct control of up to 48 fixtures 30 playback masters 300 cue lists/chases, each with a maximum of 250 cues/animations
	1 x playback master (red) and 1 x fixture master (yellow)		
<b>Protection</b>	On-screen, context-sensitive Help menus Full brownout protection via on-board mini-UPS providing five seconds of power for automatic show save		
<b>Expansion</b>	Main console expandable with up to two wings via USB connection Second DMX universe on main console possible by attaching an LSC QX1 node to USB output		
<b>Memory</b>	16GB flash memory External show backup via USB		
<b>Outputs</b>	1 x RJ45 Ethernet connector for sACN and/or Art-Net 2 x USB Type-A ports		
	1 x XLR 5-pin output connector for DMX512-A (E1-11)	2 x XLR 5-pin output connector for DMX512-A (E1-11)	3 x XLR 5-pin output connector for DMX512-A (E1-11)
<b>Power</b>	Nominal 100-240V, 50-60Hz Typical operating range of 90-260V, 45-65Hz Power input connector via IEC socket with mains cable provided /E models supplied with external UL-certified power supply, connected via 2.5mm 12V DC jack		
<b>Mechanicals</b>	Mantra Lite 490mm (w) x 330mm (d) x 80mm (h) Weight: 5kg	Mantra Lite + 1 Wing 735mm (w) x 330mm (d) x 80mm (h) Weight: 7.5kg	Mantra Lite + 2 Wings 980mm (w) x 330mm (d) x 80mm (h) Weight: 10kg
	Corrosion-resistant, powder-coated steel with rear-screened polycarbonate durable front panel Useful front-panel lip doubles as a handy carry handle		
<b>Peace of mind</b>	CE (European) and RCM (Australian) approved Two-year warranty Designed and manufactured in Australia by LSC, an Australian-owned company with over 40 years' experience in developing world-first products		

## 25 Terminology

### 25.1 Overview

The following Terms are commonly used in this Mantra Lite Operator Manual. These Terms have been adopted by LSC as the best descriptions for functions and operations performed on the Mantra Lite and may not be terms universally adopted on similar equipment.

### 25.2 Fixture.

A multi-colour LED light, moving light, dimmer or any other DMX controlled device is known as a fixture. As you patch each Fixture you give it a unique Fixture Number. A yellow fixture fader (number) controls its intensity and the touchscreen controls its attributes.

### 25.3 DMX Address.

Every Fixture has a selectable DMX starting address and this is patched to that same DMX address number on the Mantra Lite. The Mantra Lite will then automatically patch all of the remaining DMX addresses for that Fixture according to the information in that particular Fixtures Template.

### 25.4 Template.

A Fixture Template is a file that tells the Mantra Lite the function of each DMX address for that fixture and it defines the touchscreen Apps controls and labels for that Fixture. Every different type of Fixture that you control requires a Template.

### 25.5 Fixture Library.

The Mantra Lite stores its fixture templates in a library. The templates are organised in the library by manufacturer and model. When you want to use a particular model of Fixture, you select its Template from the library.

### 25.6 Attribute.

Each brand and model of Fixture has a specified number and order of control channels. An attribute is one or two DMX control channels (two channels used for higher resolution) that uniquely controls one of the physical motions of the Fixture. The manufacturer's specification of a Fixture lists each attribute and its control channel number(s). Attributes are sometimes referred to as "Parameters".

### 25.7 LTP. (Latest Takes Precedence)

See section 12.6.

### 25.8 Look

A lighting "look" is the current output of the Mantra Lite. A "look" may be made up of a collection of fixtures or one or many cues or a combination of cues plus fixtures. It may even be a single fixture.

### 25.9 Cue

A Cue is a memorised look of fixtures (at their respective levels, colours and positions) plus any animations that were running when the cue was recorded. The cue can be given a name. It can be played back on a red playback.

## 25.10 DMX512A

DMX512A is the industry standard for the transmission of digital control signals between lighting equipment. It utilises just a single pair of wires on which is transmitted the level information for the control of up to 512 DMX slots.

As the DMX512 signal contains the level information for all slots, each piece of equipment needs to be able to read the level(s) of the slots(s) that apply only to that piece of equipment. To enable this, each piece of DMX512 receiving equipment is fitted with an address switch or menu. This address is set to the slot number to which the equipment is to respond.

## 25.11 DMX Cables

Only use specific DMX cable (available from your lighting supply company). Never use audio cable. If you want to make your own cables LSC recommends using Beldon 9842 (or equivalent).

Pin Number	Function
1	Ground
2	- Data
3	+ Data
4	Not Used
5	Not Used

### DMX 5 pin XLR Pinouts

The end of the DMX line must be terminated (120 ohms) to prevent the signal reflecting back up the line and causing possible errors.

## 25.12 DMX Universes

If more than 512 DMX slots are required, then more DMX outputs are required. The slot numbers on each DMX output are always 1 to 512. To differentiate between each DMX output, they are called Universe1, Universe 2 etcetera. Mantra Lite provides one DMX universe. The optional wings and the QX1 node (USB to DMX adaptor) provide additional DMX universes.

Mantra Lite calls its universes U1, U2 and U3.

## 25.13 ArtNet

ArtNet is a streaming protocol to transport multiple DMX universes over a single cat 5 Ethernet cable/network.

## 25.14 sACN

Streaming ACN (sACN) is an informal name for the E1.31 streaming protocol to transport multiple DMX universes over a single cat 5 Ethernet cable/network.

## 26 Caring for your Mantra Lite

The Mantra Lite is manufactured from quality components and will give many years of service if you take some basic precautions.

- Do not allow any liquids or foreign objects to enter the Mantra Lite. If any liquids are spilt on the Mantra Lite, the inside should be cleaned and dried as soon as possible. Only suitably qualified personnel should remove the covers and perform any such maintenance.
- Do not apply excessive force to any of the controls. Spare parts and service are available from your LSC distributor, but prevention is better than cure.

- When connecting any devices to the Mantra Lite, make sure that all connections are correct before switching on the power. If any doubt exists, obtain the assistance of qualified personnel.

If the surface of your Mantra Lite becomes soiled, clean it with a damp cloth. Do not use any powerful solvents.

## 27 Compliance Statements

The Mantra Lite range of lighting control desks from LSC Control Systems Pty Ltd meets all required CE (European) and RCM (Australian) standards.

*CENELEC (European Committee for Electrotechnical Standardization).*



*Australian RCM (Regulatory Compliance Mark).*



**WEEE** (*Waste Electrical and Electronic Equipment*).



The WEEE symbol indicates that the product should not be discarded as unsorted waste but must be sent to separate collection facilities for recovery and recycling.

For more information about how to recycle your LSC product, contact the dealer where you purchased the product or contact LSC via email at [info@lsccontrol.com.au](mailto:info@lsccontrol.com.au)

You can also take any old electrical equipment to participating civic amenity sites (often known as 'household waste recycling centres') run by local councils. You can locate your closest participating recycling centre using the following links.

- AUSTRALIA <http://www.dropzone.org.au>.
- NEW ZEALAND <http://ewaste.org.nz/welcome/main>
- NORTH AMERICA <http://1800recycling.com>
- UK [www.recycle-more.co.uk](http://www.recycle-more.co.uk).

-END-