

# CRYO GATE

**Accessory for low fog  
to be used with CO<sub>2</sub>- high pressure tank**

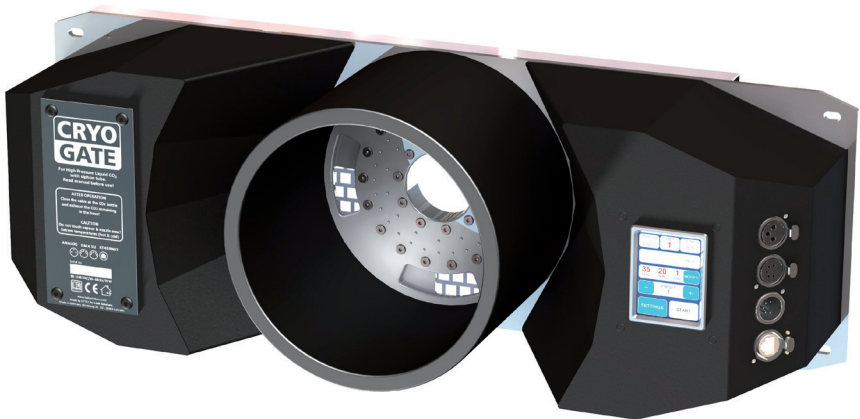

# Set of Equipment supplied

## **Cryo-Gate:**

- 1 **Cryo-Gate**
- 1 Connecting tube complete with connectors to connect the Cryo-Gate to the CO<sub>2</sub>-tank, 5 m
- 1 mains cable 2 m Powercon True plug
- 1 Inline-Filter
- 1 Operating manual

## **Cryo-Gate Complete:**

- 1 **Cryo-Gate** installed in flightcase
- 1 Connecting tube complete with connectors to connect the Cryo-Gate to the CO<sub>2</sub>-tank, 5 m
- 1 mains cable 2 m Powercon True plug
- 1 Inline-Filter
- 1 Flightcase with storage space for outlet hose and connection hose CO<sub>2</sub>
- 1 Outlet hose 10 m, 200 mm ø
- 2 Caps for outlet hose
- 1 Operating manual

Please check whether all the products you ordered are supplied.

# Content

<b>1. Introduction</b>	<b>4</b>
<b>2. Safety instructions</b>	<b>5</b>
<b>3. Descriptions of the parts</b>	<b>6</b>
<b>4. Operating the Cryo-Gate</b>	<b>8</b>
4.1 Putting into operation	8
4.1.1 Setting up and connecting a fog machine	8
4.1.2 Connecting the high pressure CO <sub>2</sub> -tank with siphon tube	8
4.1.3 Connecting external controls	8
4.1.4 Power supply	9
4.2 Switching the device off	9
4.3 Changing the CO <sub>2</sub> -tank	9
4.4 Operation	10
4.4.1 Main menu	10
4.4.2 Status bar	11
4.4.3 Display Standby	11
4.5 Working with Presets	12
4.6 Working with Sources	12
4.6.1 Manual operation	13
4.6.2 Operating via DMX	14
4.6.3 Operating via analog	15
4.6.4 sACN	16
4.6.5 Art-Net	17
4.6.6 Operating via Timer	18
4.6.7 RDM	20
4.7 Settings	21
4.7.1 Fog machine	21
4.7.2 CO <sub>2</sub> usage	22
4.7.3 Personality	23
4.7.4 Ethernet	24
4.7.5 Display	25
4.7.6 Vent CO <sub>2</sub>	26
4.7.7 Standby	26
4.7.8 Info	26
4.7.9 Update	27
4.7.10 Reset	27
4.8 DMX-Channel assignment	28
<b>5. Error messages</b>	<b>29</b>
5.1 Air vent failure	29
5.2 E-4	29
5.3 E-20 und E-21	30
<b>6. Update</b>	<b>31</b>
<b>7. Cleaning, Care and Maintenance</b>	<b>32</b>
<b>8. Specifications</b>	<b>33</b>
8.1 Connections / 8.2 Wiring of the connectors	33
<b>9. Warranty conditions</b>	<b>34</b>

# 1. Introduction

The **Cryo-Gate** is a compact device that mates up to any professional fogger. It enables the user to temporarily transform their existing fogger into a low fog generator.

The **Cryo-Gate** sits in front of the fogger's nozzle. A high-pressure dip-tube siphon CO<sub>2</sub> tank connects to the unit and allows the user to add a variable amount of CO<sub>2</sub> and air to the fog's output. The result is a cold fog that stays low.

The connector to connect the delivered safety tube to the bottle has to be a W 21.8 x 1 1/4" right male (CGA 320 connector). If a tank with this connector cannot be found, you have to use an adaptor.

A tube (Ø 200 mm) can be connected to the front of the **Cryo-Gate** to guide the fog into the requested direction.

The tube can be around ten meters long, allowing to place the machine away from the stage to avoid disturbing noise.

If you have not chosen the **Cryo-Gate Complete** and want to construct your own flight case, holes make it easy to install the **Cryo-Gate** in a flight case or mount it to rack rails.

**Please note:** Only use quick disappearing fog fluid to avoid the chance that the fog will get warm and rises.

Also cooled down fog will rise after some time!

**Please read the manual carefully before starting the device to ensure a correct operation!**

## 2. Safety Instructions

### A fog machine is not a toy!

- Make sure, that all persons who work with the bottle and the gas are professionals. Incorrect use can cause the risk of suffocation!
- Carbon dioxide is not toxic but may cause asphyxiation in high concentrations.
- Carbon dioxide is heavier than air. The highest concentration is therefore at floor level. The maximum allowed concentration is 0.5 Vol% (MAK: 5.000 ppm).
- Ensure adequate ventilation.
- Ensure all national/local regulations for handling and storage of liquid carbon dioxide (CO<sub>2</sub>) are observed.
- Avoid dust or dirt particles inside the CO<sub>2</sub>-hose. Always ensure complete purity of all CO<sub>2</sub>-connectors and fittings
- Extreme temperatures at the nozzle (hot/cold)! Danger of burning/frostbite.
- Occasionally very hot droplets of fluid may escape when in operation. Never aim at persons directly and keep a minimum distance of 3 m from the nozzle.
- Never touch the nozzle when in operation. Danger of getting burnt.
- The location of the machine must be non-flammable, non-combustible and not sensitive to heat. It must be twice as big as the machine.
- Keep a minimum distance of 60 cm to all flammable, combustible objects and objects sensitive to heat.
- Glycol is alcohol and burns with a slightly bluish, almost invisible flame. Never point the fog at strong sources of ignition like fire or pyrotechnic effects.
- Never open the machine and leave the machine unattended when connected to a power supply.
- The visibility must be more than 2 m in rooms where people walk around.
- Do not swallow the fog liquid. Keep it away from children. In case of eye contact, rinse with a lot of water. Consult a doctor should you accidentally swallow some fluid.

## 2. Safety Instructions

- Spilled liquid or splashed liquid droplets can cause slip hazard. Mop up the fluid and dispose of it according to regulations.
- Fog may activate smoke detectors.

Artificially-made fog can be produced in many different ways. The method used here to produce fog, with a device which works according to the vaporizer principle, is the most harmless one.

No case has so far been reported in which a healthy human being has been harmed because of using our device to produce artificial fog. However, this can only be guaranteed if the professional fog generators are used appropriately, i.e. at the correct vaporization temperatures as well as with the correctly mixed fog fluid.

We, however, recommend: People with health problems or problems of the respiratory tract or with an inclination for allergies should avoid any contact with artificially-made fog.

## 3. Description of the parts

Front view

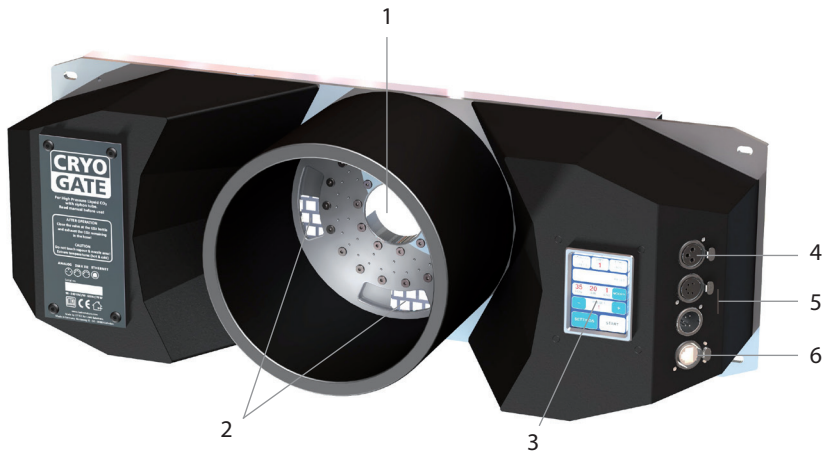

- 1: Fog nozzle
- 2: Air vents
- 3: Touchscreen

- 4: Analog in 3pin-XLR
- 5: DMX512 in/out 5pin-XLR
- 6: Ethernet-Connector RJ45/Ethercon

### 3. Description of the parts

#### Rear view

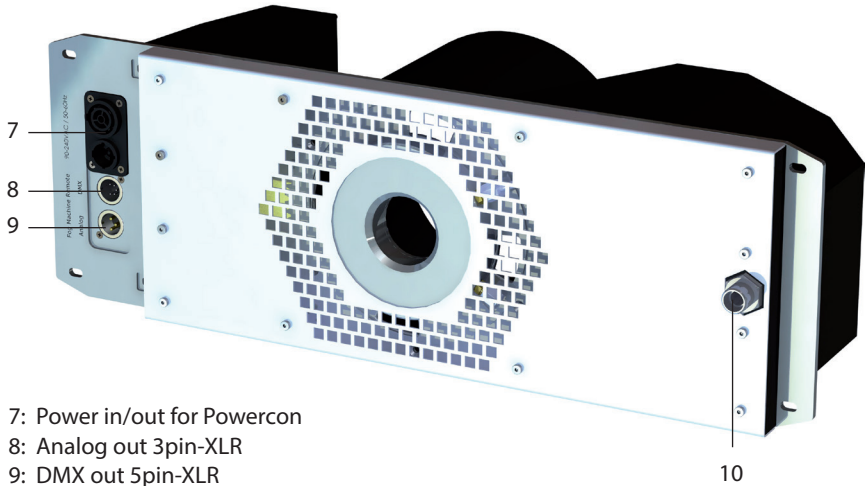

- 7: Power in/out for Powercon
- 8: Analog out 3pin-XLR
- 9: DMX out 5pin-XLR
- 10: Connector for liquid-CO<sub>2</sub>-tube

#### Connection to the high pressure CO<sub>2</sub>-tank with siphon tube

- Avoid dust or dirt particles inside the CO<sub>2</sub>-hose!
- Always ensure complete purity of all CO<sub>2</sub>-connectors and fittings!

11: CO<sub>2</sub>-hose

12: CO<sub>2</sub>-connector Europe

13: T-connector to connect several CO<sub>2</sub>-tanks (available as an option)

13: Valve

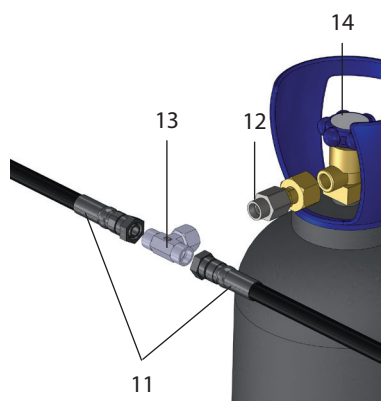
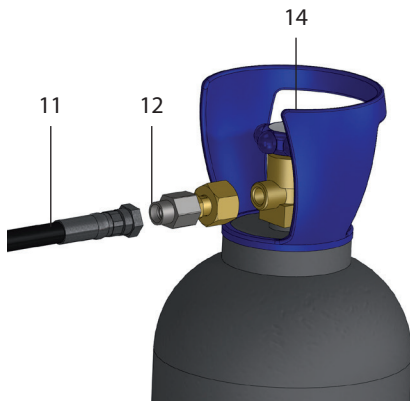

## 4. Operating the Cryo-Gate

### 4.1 Putting into operation

#### 4.1.1 Setting up and connecting a fog machine

- Set up a fog machine approved by the manufacturer behind the **Cryo-Gate**. The fog outlet of the fog machine should be placed centrally at a distance of approx. 1 to 2 cm from the fog outlet of the **Cryo-Gate**.
- If the fog machine has a PowerCon True1 input (up to max. 3 kW/1.8 kW for USA), it can be supplied via the PowerCon True1 output [7] of the **Cryo-Gate**. If not, connect the machine to a supply according to its instructions

**Note:** Only set up a fog machine approved by the manufacturer!

- Connect a communication cable between the **Cryo-Gate** and the fog machine. If possible, connect the DMX output [9] of the **Cryo-Gate** to the fog machine.  
**If the fog machine is connected to the Cryo-Gate via DMX, make sure that the DMX start address „1“ is set on the fog machine.**

#### 4.1.2 Connecting the high power-CO<sub>2</sub>-tank with siphon tube

- Connect a CO<sub>2</sub> tank and the corresponding connection on the **Cryo-Gate** [10] with the supplied safety hose (see p. 7). **Make sure that the threads and screw connections are clean.**
- If you find impurities in the hose, first connect it to the CO<sub>2</sub> tank and briefly open the valve on the cylinder to flush the hose with CO<sub>2</sub>.
- Tighten both hose connections firmly with a suitable tool (wrench size 22) so that no CO<sub>2</sub> can escape uncontrolled. Open the valve [14] on the bottle completely.

#### 4.1.3 Connecting external control

- Connect - if required - cables for external control such as DMX, Ethernet or a remote control.

**Note:** Use only suitable cables for connection!  
DMX cables must be suitable and shielded for digital data transmission!  
Ethernet cables must be at least category 5e and shielded!

## 4. Operating the Cryo-Gate

### 4.1.4 Power Supply

- Connect the enclosed power cord to the device by inserting the plug into the connector and turning it until it audibly clicks into place. Insert the power plug into an grounded socket.

**Warning:**

Use only the enclosed power cord or another cord approved by the manufacturer!  
Connect the device only to grounded sockets!

- The **Cryo-Gate** performs an initialization and is then ready for operation.
- The connected fog machine may need time to reach the operating temperature!  
Please read the operating instructions of the fog machine.

### 4.2 Switching the device off

- Close the valve on the CO<sub>2</sub> tank [14]. Make sure the valve is really completely closed.
- Release the remaining CO<sub>2</sub> off the hose, using **Vent CO2** (see section 4.7.6).  
Alternatively, you can also use the CO<sub>2</sub> channel via DMX, Ethernet or via the analog remote control (see section 4.6.3).
- Then unplug the power cord from the outlet and/or remove the PowerCon True1 connector from the port.
- If the fog machine is not connected to the PowerCon True1 output, make sure that you switch it off as well!

### 4.3 Changing the CO<sub>2</sub> tank

- Close the valve on the CO<sub>2</sub> tank [14]. Make sure the valve is really completely closed.
- Release the remaining CO<sub>2</sub> off the hose, using **Vent CO2** (see section 4.7.6).  
Alternatively, you can also use the CO<sub>2</sub> channel via DMX, Ethernet or via the analog remote control (see section 4.6.3).
- Disconnect the connection between the CO<sub>2</sub> hose and the bottle and connect the hose to a new bottle.

## 4. Operating the Cryo-Gate

### 4.4 Operating

#### 4.4.1 Main menu

After switching on the device, the main menu is displayed.



Fig. 1 Main menu

The main menu is divided into several sections, each of which contains specific information or settings:

- Top left: Source: Displays the currently active source. Tapping leads to the *Select source* menu. Working with sources is described in section 4.6.
- Top right: Displays information about the current source. Tapping leads to the settings menu of the active source. If the center is highlighted, a valid signal is received from the source. The information displayed is described for the individual sources.
- Center top: Used CO2: Displays the used value of CO<sub>2</sub>-Menge an. Tapping leads to the CO<sub>2</sub> menu, like described in section 4.7.2.
- Center bottom: Preset: The current preset is displayed and can be changed.
- Bottom: Settings and display of the individual values: The values *Fog*, *Air* and *CO2* are displayed. Tapping  leads to manual operation (see section 4.6.1). Tapping *Start* starts the device with the displayed settings. Tapping *Settings* leads to the settings menu.

## 4. Operating the Cryo-Gate

### 4.4.2 Status bar

The status bar is always on top of the display and shows the most important information. These are from left to right:



Fig. 2 Status bar with icons

- Activity icon: Indicates play (▶) when the device is active, otherwise pause (⏸)
- Analog icon (⏸): Indicates if a signal from a remote control is present
- DMX icon (☺): Indicates whether a DMX signal is being received
- Art-Net icon (⏸): Indicates if Art-Net data is being received
- sACN icon (⏸): Indicates whether sACN data is being received
- Ethernet icon (↔): Indicates the status of Ethernet.  
Icon without IP address: Connected, but no IP address available  
Icon and IP address: Connected and valid IP address present  
Rot: Connected, but no IP address obtained via DHCP
- Timer icon (⌚): Indicates whether the integrated timer is running.

### 4.4.3 Display Standby



Fig. 3 Display Standby

When the signal from the active source is lost, the machine is put into standby.

This switches off the pump and the heating element and the display goes into screen saver. Before going into standby, the display shows a notice with a countdown of 10 seconds.

It is also possible to switch to standby via the settings menu.

To exit the standby, you can

- touch the display
- reconnect the current source

If the DMX Personality is set to 5-channel mode, you can enter or exit standby using channel 5 (see section 4.7.3).

## 4. Operating the Cryo-Gate

### 4.5 Working with Presets

To simplify operation via the analog remote control, the timer or the display, the device has up to 6 presets in which the values can be programmed.

Presets 1, 2 and 3 are fixed and cannot be changed. Presets 4, 5 and 6 can be programmed by the user.

Preset	Fog	Air	CO2	Programmable
1	35	20	1	No
2	45	30	2	No
3	50	30	3	No
4	-	-	-	Yes
5	-	-	-	Yes
6	-	-	-	Yes

Fig. 4 Standard values for presets

To create a new preset, the required values must be set via the manual operation (see section 4.6.1). In the *Manual mode* menu, these can be saved via *Save Preset*.

After selecting Preset 4, 5 or 6, the values are saved with *Save*. The preset can now be used via the main menu or the settings for the timer or the analog remote control.

### 4.6 Working with Sources

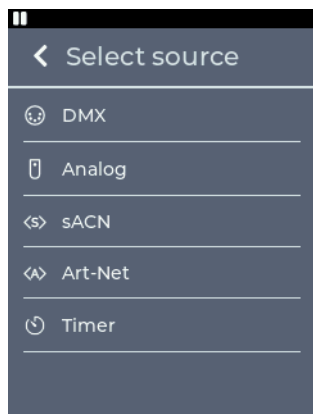

Fig. 5 Menu Sources

In the present version of **Cryo-Gate**, the previous hierarchical system is replaced by a system with source selection, which is based on the source selection on a TV, for example.

Basically, a set source is used until it is changed on the machine.

However, there are some exceptions to this rule:

1. **DMX** is selected as source  
If the DMX signal is lost and the analog remote control is used, the source is automatically changed to **Analog**.
2. **Analog** is selected as source  
If the **Cryo-Gate** receives a DMX signal again, the source is automatically changed to **DMX**.

## 4. Operating the Cryo-Gate

3. **Timer** is selected as source

If the **Cryo-Gate** receives a DMX signal again, the source is automatically changed to **DMX**.

4. **Manual** operation via Display

Manual operation is only possible if the selected source is not active. If it becomes active, manual operation is automatically terminated.

### 4.6.1 Manual operation



Fig. 6 Manual mode



Fig. 6a Manual mode, all outputs active

The value can be changed by pressing + and - on the respective value.

Press ► to start the value, press ■ to stop it again (Fig. 6/6a).

With **Start all** all values can be started, with **Stop all** they can be stopped again.

Alternatively, all values in the main menu can be started with **Start** or stopped with **Stop**. The values can be saved as a preset (see section 4.5).

## 4. Operating the Cryo-Gate

### 4.6.2 DMX

The source setting **DMX** is the default of the device. The main menu displays the current DMX address and the status of the DMX connection.



Fig. 7 Main menu DMX



Fig. 7a Adjustments DMX

Tapping the **DMX** button or **Source** -> **DMX** switches to the DMX settings menu. Here the DMX address can be set.

Pressing + and - increases or decreases the number on the flashing cursor.

Pressing < and > or tapping directly on a digit moves the cursor.

Pressing < in the upper left corner returns to the previous screen without saving the changes.

Pressing ✓ will save the settings and return to the main menu. DMX is now selected as source.

The device occupies between three and five DMX channels. The channel assignment can be changed via the **Personality** setting (see section 4.7.3).

The **Cryo-Gate** supports RDM in DMX mode (see section 4.6.7).

## 4. Operating the Cryo-Gate

### 4.6.3 Analog



The **Analog** source setting can be used to control the unit via a remote control. In the main menu, the current analog mode and status are displayed.

Tapping the **Analog** button or by **Source** -> **Analog**, switches to the Analog settings menu. Here the mode can be changed.

Fig. 8 Main menu Analog



Fig. 8a Adjustment Flash



Fig. 8a Adjustment Toggle

In **Flash** mode it is possible to switch between two preselected presets. It corresponds to the DIRECT mode on the version 1 and 2 machines. To create presets, see section 4.5.

If the remote control is between 10% and 60%, the first selected preset is started, between 60% and 100% the second one.

In **Toggle** mode, a short voltage pulse starts the selected preset. Another impulse terminates the preset.

It corresponds to the LATCHED mode on the version 1 and 2 machines, which allows to use the available radio remote control in combination with the machine.

## 4. Operating the Cryo-Gate

In contrast to the devices version 1 and 2, the toggle mode can also be terminated by switching to flash mode or changing the source.

Pressing < in the upper left corner returns to the previous screen without saving the changes.

Pressing ✓ will save the settings and return to the main menu. Analog is now selected as source.

### 4.6.4 sACN

The **sACN** source setting allows the device to be controlled via network using the sACN protocol. The main menu displays the current sACN universe, the start address and the status of the connection.



Fig. 9 Main menu with sACN



Fig. 9a Settings sACN

Tapping the **sACN** button or **Source** -> **sACN** switches to the sACN-settings. Here the Universe and address can be set.

Pressing + and - increases or decreases the number on the flashing cursor.

Pressing < and > or tapping directly on a digit moves the cursor.

In the upper row the sACN universe is set. The value can be between 1 and 63999.

In the lower row the DMX address of the **Cryo-Gate** in the selected universe is set. The value can be between 1 and 512.

Pressing < in the upper left corner returns to the previous screen without saving the changes.

## 4. Operating the Cryo-Gate

Pressing ✓ will save the settings and return to the main menu. sACN is now selected as source.

To receive sACN data, the device must be connected to a network and have a valid IP address. The settings for this are described in section 4.7.4.

The device occupies between three and five DMX channels. The channel assignment can be changed via the *Personality* setting, see section 4.7.3.

### 4.6.5 Art-Net



Fig. 10 Main menu with Art-Net

The *Art-Net* source setting allows the unit to be controlled via the Art-Net protocol by network.

In the main menu, the current Art-Net configuration and the status of the connection are displayed.

Tapping the *Art-Net* button or *Source* -> *Art-Net* switches to the Art-Net settings. Here the Net, Sub-Net, Universe and the address can be set.



Fig. 10a Settings Art-Net



Fig. 10b Settings Art-Net

## 4. Operating the Cryo-Gate

Pressing + and - increases or decreases the number on the flashing cursor.  
Pressing < and > or tapping directly on a digit moves the cursor.

In the upper row the Art-Net-Net is set. The value can be between 0 and 127.

In the next row, the Art-Net Sub-Net is set. The value can be between 0 and 15.

In the next row the Art-Net-Universe is set. The value can be between 0 and 15.

In the bottom row the DMX address of the machine in the selected universe is set. The value can be between 1 and 512.

Pressing < in the upper left corner returns to the previous screen without saving the changes.

Pressing ✓ will save the settings and return to the main menu. Art-Net is now selected as source.

To receive Art-Net data, the device must be connected to a network and have a valid IP address. The settings for this are described in section 4.7.4.

The **Cryo-Gate** occupies between three and five DMX channels. The channel assignment can be changed via the *Personality* setting, see section 4.7.3.

The device supports RDM in Art-Net mode (see section 4.6.7).

### 4.6.6 Timer



The source setting *Timer* can be used to control the device via an integrated timer. The current status of the timer is displayed in the main menu. If the timer is running, the active and waiting time is displayed.

Tapping the *Timer* button or *Source* -> *Timer*, you can switch to the Timer settings menu.

Fig. 11 Main menu with Timer

## 4. Operating the Cryo-Gate

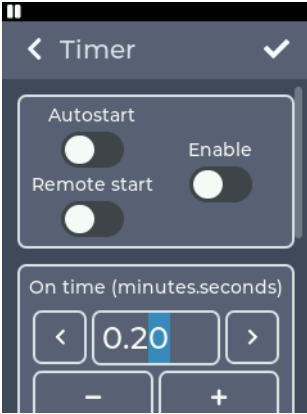

In the top box the start options can be changed.

- **Autostart:** After switching on the device, the timer starts automatically
- **Remote start:** The timer is started by a short pulse at the analog input and continues to run normally
- **Enable:** After saving the settings, the timer starts running

Fig. 11a Timer settings

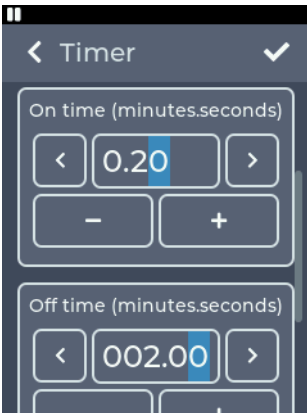

By scrolling, the „On time“ for the timer can be configured in the second box - the time during which the timer runs.

The time can be set between 2 seconds and 4 minutes.

Press + and - to increase or decrease the number on the flashing cursor.

Pressing < and > or directly tapping a digit can move the cursor.

Fig. 11b Setting On time



By scrolling again, the "Off time" (pause time) can be configured in the third box.

The time can be set between 10 seconds and 120 minutes.

By scrolling further, the preset to be used can be set in the fourth box. To create presets, see section 4.5.

Fig. 11c Setting Off time and Preset

## 4. Operating the Cryo-Gate

Pressing < in the upper left corner returns to the previous screen without saving the changes.

Pressing ✓ will save the settings and return to the main menu. Timer is now selected as source. If the **Enable** option was turned on, the timer will start.

If the info area for the timer is tapped in the main menu while the timer is running, the timer is stopped. If you tap the info area again while the timer is stopped, the timer settings menu appears.

### 4.6.7 RDM

When used with DMX and Art-Net the machine supports the RDM protocol. Via RDM properties can be read and changed.

The following parameters are supported:

Parameter	Disc	GET	SET
DISC_UNIQUE_BRANCH	✓		
DISC_MUTE	✓		
DISC_UN_MUTE	✓		
QUEUED_MESSAGE		✓	
STATUS_MESSAGES		✓	
SUPPORTED_PARAMETERS		✓	
DEVICE_INFO		✓	
DEVICE_MODEL_DESCRIPTION		✓	
MANUFACTURER_LABEL		✓	
DEVICE_LABEL		✓	✓
SOFTWARE_VERSION_LABEL		✓	
DMX_PERSONALITY*		✓	✓
DMX_PERSONALITY_DESCRIPTION		✓	
DMX_START_ADDRESS		✓	✓
SLOT_INFO		✓	
SLOT_DESCRIPTION		✓	
DEFAULT_SLOT_VALUE		✓	
SENSOR_DEFINITION		✓	
SENSOR_VALUE		✓	✓
DEVICE_HOURS		✓	
DISPLAY_LEVEL		✓	✓
DISPLAY_INVERT		✓	✓
IDENTIFY_DEVICE		✓	✓
RESET_DEVICE			✓

\*DMX Personalities are described in section 4.7.3.

### Sensors

The device has the following sensors that can be read out via RDM:

- **CO2 usage:** Displays CO2 consumption, rounded to the next kilogram.

## 4. Operating the Cryo-Gate

### 4.7 Settings

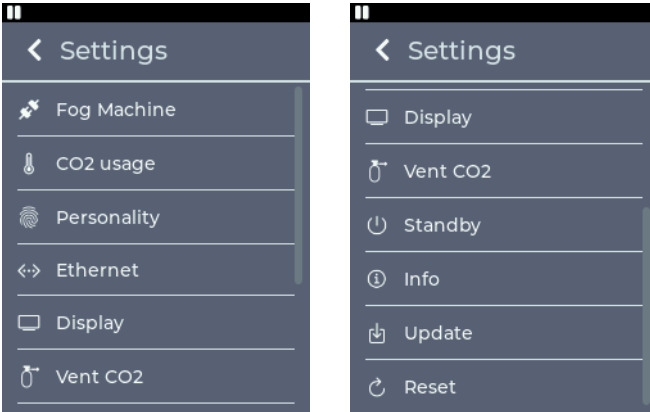

Fig. 12 Menu Settings

By tapping the **Settings** button in the main menu, you can switch to the settings menu. All general settings can be adjusted here. To return to the main menu, < must be pressed in the upper left corner.

#### 4.7.1 Fog Machine

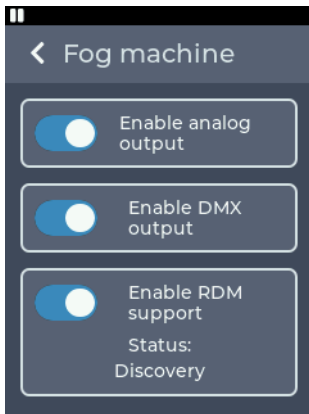

Fig. 13 Setting Fog machine

In the **Fog machine** menu, the settings for controlling the connected fog machine can be changed.

The following settings are possible:

- The analog output to the fog machine can be disabled.
- The DMX output to the fog machine can be disabled.
- RDM to the fog machine can be disabled.

The **Cryo-Gate** supports RDM capable fog generators like the **Cobra 3.1**.

If an RDM-capable machine is detected, the DMX address of the fog machine is automatically set to 1.

## 4. Operating the Cryo-Gate

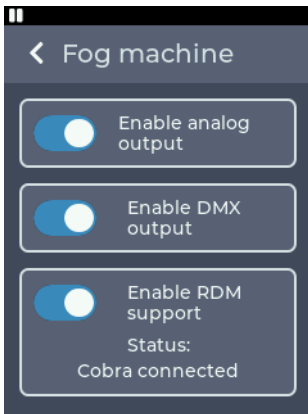

Fig. 13a Setting Fog machine with detected fog machine

Further the Personality of the machine is changed, if it is changed at the device itself (see section 4.7.3):

- 3 channel-Mode: The fog machine is set to the 1 channel-Mode
- 4 and 5 channel-Mode: The fog machine is set to 2 channel-Mode

If problems occur, RDM can be switched off.

### 4.7.2 CO<sub>2</sub> usage



Fig. 14 Setting CO<sub>2</sub> usage

In the **CO<sub>2</sub> usage** menu, the CO<sub>2</sub> consumed can be monitored and reset, and the unit can be changed.

- The upper field shows the CO<sub>2</sub> consumption since the last reset
- In the middle field the unit can be changed between kilograms and pounds (lbs)
- In the lower field the consumption can be reset to 0. This allows the consumption to be measured after connecting a new cylinder.

The menu can also be entered from the main menu, see section 4.4.1.

## 4. Operating the Cry-Gate

### 4.7.3 Personality

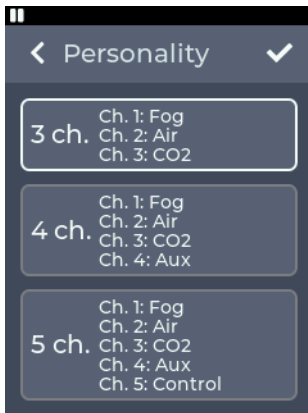

Fig. 15 Setting Personality

In the *Personality* menu the number of used DMX channels can be adjusted.

This adjustment can also be done via RDM, see section 4.6.7.

The DMX channel assignment is described in section 4.6.2.

The following settings are possible:

- **3 ch.:**
  - Channel 1: Fog intensity: Fog output of the connected fog generator
  - Channel 2: Air: Ventilation slots opening
  - Channel 3: CO<sub>2</sub>: Amount of CO<sub>2</sub> output (1, 2, 3 kg/min.)

- **4 ch.:**
  - Channel 1: Fog intensity: Fog output of the connected fog generator
  - Channel 2: Air: Ventilation slots opening
  - Channel 3: CO<sub>2</sub>: Amount of CO<sub>2</sub> output (1, 2, 3 kg/min.)
  - Channel 4: Aux channel for the connected fog generator: for example setting of the pump curve at a Cobra 3.1
- **5 ch.:**
  - Channel 1: Fog intensity: Fog output of the connected fog generator
  - Channel 2: Air: Ventilation slots opening
  - Channel 3: CO<sub>2</sub>: Amount of CO<sub>2</sub> output (1, 2, 3 kg/min.)
  - Channel 4: Aux channel for the connected fog generator: for example setting of the pump curve at a Cobra 3.1
  - Channel 5: Control: Can put into standby or reactivate the device via DMX

Pressing < in the upper left corner returns to the previous screen without saving the changes. Pressing ✓ will save the settings and return to the main menu.

**Note:**

The higher the CO<sub>2</sub> output, the colder and flatter the low fog.

## 4. Operating the Cryo-Gate

### 4.7.4 Ethernet

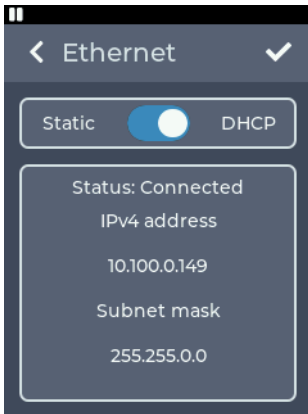

Fig. 16 Setting Ethernet DHCP

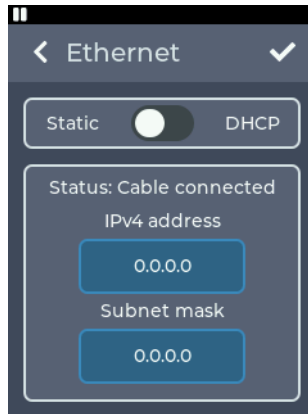

Fig. 16a Setting Ethernet Static



Fig. 16b Setting of a manual address

In the *Ethernet* menu, settings for the network connection such as DHCP or a static IP address can be configured.

The upper switch can be used to set whether an IP address is to be obtained via DHCP or whether a static IP address is to be configured.

If *DHCP* is selected as the setting, the IP address and subnet mask assigned by the DHCP server in the network are displayed below.

If *Static* is selected as the setting, buttons for entering the IP address and subnet mask are displayed below.

If the buttons are tapped, a keyboard for entering the IP address or subnet mask is displayed.

Pressing < in the upper left corner returns to the previous screen without saving the changes.

Pressing ✓ will save the settings. If a non-valid address is entered, the previous address is retained!

If no server in the network responds when *DHCP* is set, a random IP address is selected after approx. 15 seconds using the Auto IP protocol. An attempt is still made to obtain an address from a DHCP server.

## 4. Operating the Cryo-Gate

### 4.7.5 Display

In the *Display* menu, settings for the display such as the brightness and the screen saver can be configured.

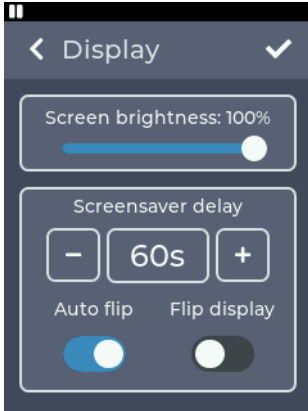

Fig. 17 Setting Display



Fig. 17a Screen saver

In the upper area, the brightness of the display can be set in 10% steps between 10% and 100%.

In the lower area, the time after which the screen saver is activated can be set. A time from 20 to 120 s in 10 s steps is possible. The screen saver is the logo that jumps around randomly.

Below this, you can set whether the display should rotate automatically when the device is turned over.

If automatic rotation is deactivated, the display can also be rotated manually.

Pressing < in the upper left corner returns to the previous screen without saving the changes.

Pressing ✓ will save the settings.

## 4. Operating the Cryo-Gate

### 4.7.6 Vent CO2

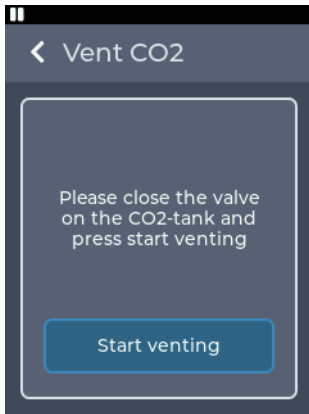

Fig. 18 Setting Vent CO2

In the **Vent CO2** menu, the CO<sub>2</sub> remaining in the hose can be drained before the device is switched off.

After the valve of the cylinder has been turned off, the remaining CO<sub>2</sub> can be drained with **Start venting**.

During this time, the unit cannot be operated from any other source!

### 4.7.7 Standby

Tapping **Standby** directly displays the standby screen (see section 4.7.7).

### 4.7.8 Info

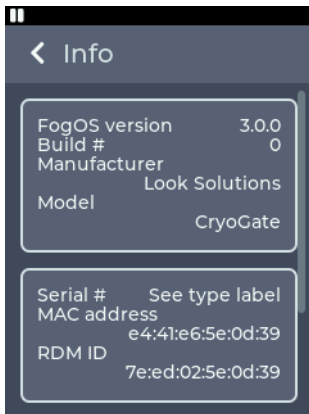

Fig. 19 Info menu

The **Info** menu displays information about the machine. This includes the model, the software version and the MAC address and RDM ID.

Additional information such as the hour counter and temperatures can be found under **Additional information** at the bottom of the menu.

License information can be found under **License information**.

## 4. Operating the Cryo-Gate

### 4.7.9 Update



Fig. 20 Update menu

The current update code for the device is displayed in the *Update* menu. This can be used to start the update process, see section 6.

### 4.7.10 Reset

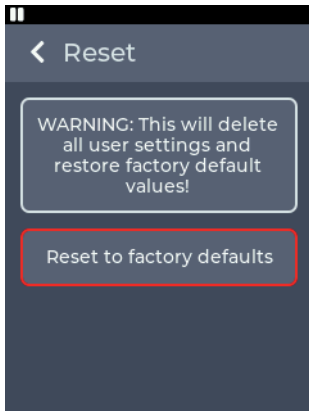

Fig. 21 Reset menu

In the *Reset* menu, the device can be reset to the factory defaults.

After pressing Reset to factory defaults, the device is restarted and the factory defaults are loaded.

The following settings cannot be reset:

- Operating hours counter

## 4. Operating the Cryo-Gate

### 4.8 DMX-Channel assignment

The channel assignment depends on the set Personality (see section 4.7.3).

Mode			DMX Value	Function	Type of control
1	2	3			
1	1	1		<b>Fog output</b>	
			0 - 255	0 to 100%	proportional
2	2	2		<b>Air</b>	
			0 - 255	Air vent opening	proportional
3	3	3		<b>CO2</b>	
			0 - 64	Off	
			65 - 129	1 kg / minute	step
			130 - 194	2 kg / minute	step
			195 - 255	3 kg / minute	step
*	4	4		<b>Aux channel</b>	
			0 - 255	Value will be passed through to the external for machine on DMX channel 2	proportional
*	*	5		<b>Control</b>	
			0 - 25	Reserved	
				To activate the following functions, stop at DMX value for at least 5 sec. and fog output must be 0 for at least 1 sec.	
			26 - 100	Activate standby	step
			101 - 255	Deactivate standby	step

# 5. Error messages

## 5. Error messages

If an error is shown on the display, the machine must be restarted in order to continue using it after the error has been corrected. The machine can report the following errors:

### 5.1 Air vent failure

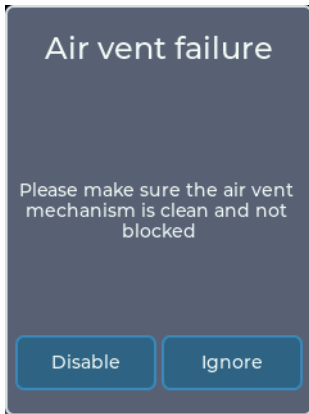

Fig. 22 Air vent failure

An error has occurred during initialization of the air opening.

The flap cannot be moved correctly because the duct is heavily soiled or blocked by an object.

By **Disable** the air vent can be deactivated, the rest of the device works normally.

**Ignore** activates the air vent anyway, malfunctions may occur!

### 5.2 E-4



Fig. 23 Error E-4

The temperature on the board is too high.

Please contact your dealer or the manufacturer for further support.

## 5. Error messages

### 5.3 E-20 und E-21



Fig. 24 Error E-20



Fig. 24a Error E-21

Communication with the Power PCB has failed. Please contact your dealer or the manufacturer for further support.

## 6. Update

### 6. Update of the machine

The *FogOS Updater* is required to update the device. The software runs on computers with Windows or MacOS. The computer and the device must be connected to the same network and the computer must have an active internet connection.

#### Note

If the computer has a wireless Internet connection, the machine can also be connected directly to the computer with a network cable.

The operating system must support Auto-IP for this (standard for modern operating systems)!

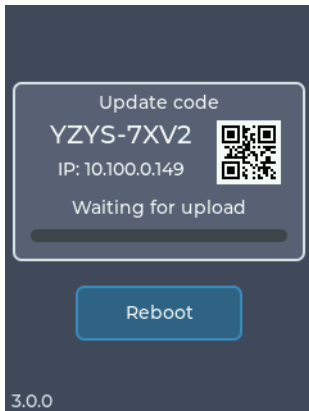

Fig. 25 Update mode

The device displays an update code under *Settings* -> *Update* (see section 4.7.9). This is entered in the FogOS Updater.

If the device is found in the network and an update is available, the device is set to update mode and the update is automatically uploaded and installed.

Afterwards, the device restarts.

#### Note

If no software for operation is found on the device, the update mode is entered automatically.

## 7. Cleaning, Care and Maintenance

- Avoid dust or dirt particles inside the CO<sub>2</sub>-tube.
- Always ensure complete purity of all CO<sub>2</sub>-connectors and fittings.
- Exhaust fittings and connecting tube with CO<sub>2</sub> before connecting to the **Cryo-Gate**.
- Take care that the connected fog machine can not get overheated.
- Wipe up spilled fluid immediately. Moisture - also fluid - can destroy the electric parts of the machine.
- If the **Cryo-Gate** is been used with a tube, there will be some residues in the tube and also the machine after a while.  
Please disconnect the tube from the duct adaptor from time to time and wipe the inside with an absorbant cloth while the machine is disconnected from the mains.
- If the **Cryo-Gate** is used for a fixed installation, make 100% sure that permanent fog-free air supply for the unit is guaranteed. Cooling air with too high fog concentration (very often in Clubs or Discos) can condense inside the connected fog machine and cause moisture damage.
- For cleaning the surface of the device use a suitable, solvent-free cleaner.

## 8. Specifications

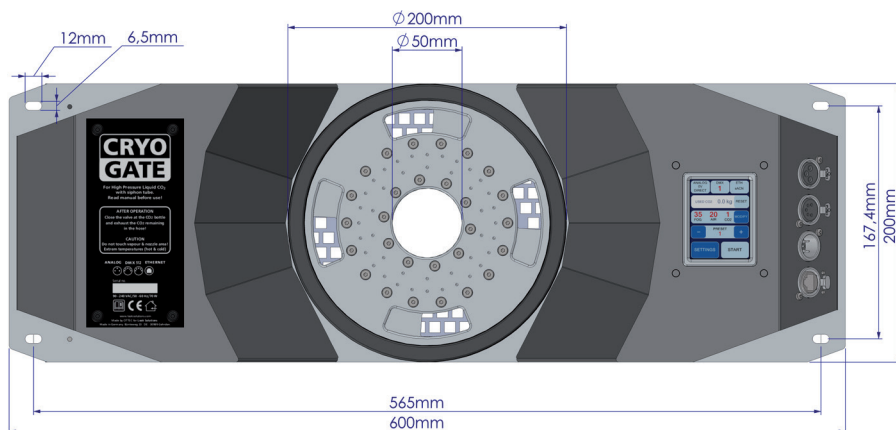

Voltage	90 bis 240 VAC
Power frequency	50/60 Hz
Power requirement max.	65 Watt
Dimensions (W x H x D)	60 x 20 x 17.7 cm
Gewicht	10.5 kg

### 8.1 Connectors

#### Power supply

- PowerCon True1 Input
- PowerCon True1 Output for fog generator

#### Communication

- DMX512 Input: 5 pin XLR male
- DMX512 Output: 5 pin XLR female
- Analog remote: 3 pin XLR female
- Ethernet: EtherCon (RJ45)
- DMX-512 Output for fog generator: 5 pin XLR female
- Analog Output for fog generator: 3 pin XLR male

### 8.2 Wiring of the connectors

#### 5pin XLR (DMX):

Pin 1 = Ground, Pin 2 = DMX -, Pin 3 = DMX +, Pin 4 u. 5 = nc

#### 3pin XLR (analog):

Pin 1 = Ground, Pin 2 = 0-10 V + DC in, Pin 3 = 12 V + DC out, max. 50 mA

Manufactured in Germany for:

Look Solutions GmbH & Co. KG • Bünteweg 33 • D - 30989 Gehrden • [www.looksolutions.com](http://www.looksolutions.com)

## 9. Warranty conditions

For the low fog machine **Cryo-Gate Look'** warranty is:

1. Free of charge, subject to the following conditions (No. 2 - 6) we will repair any defect or fault in the unit if it is caused by a proven factory fault and has been advised immediately after identification and within 12 months of delivery to the end user. Insignificant deviations of the regular production quality does not guarantee replacement rights, nor do faults or defects caused by water, wrong fog fluid, by generally abnormal environment conditions or Force Majeure.
2. Warranty Service will be done in the following way: Faulty parts will be repaired or replaced (our choice) with correct parts. Faulty units have to be returned to us or our service centres or to be sent to us or our service centres at customer's expense. The invoice and/or receipt showing the purchase date and the serial number has to come with the faulty unit, otherwise the repair will not be covered under warranty. Replaced parts become our property.
3. The customer loses all rights for warranty services if any repairs or adjustments are done to the units by unauthorized persons and/or if spare parts are used which are not approved by us. The right of warranty service is also lost if liquids/fluids other than the original Look fog fluids have been used or if units are sent to us with full fluid bottles. Also non compliance with the instructions in this manual or mistakes by incorrect handling/treating of the machine will lead to a loss of warranty and also any faults and damages caused by undue force.
4. Any freight costs arising in connection with the warranty services have to be born by the customer.
5. Warranty services do not cause an extension of the warranty time or the start of a new warranty time. The warranty for replaced parts ends with the guarantee time of the whole unit.
6. We may, at our opinion, replace the machine rather than repair it.
7. Further claims, especially for damages, losses etc. outside the unit are excluded.

Other guarantee regulations may be valid outside the USA. Please check with your dealer!

If you should send the unit for service, do not forget to remove any liquid from the fluid bottle.

For warranty service in North America contact:

Look Solutions USA Ltd.  
1-800-426-4189  
usa@lookolutions.com

